

INSTRUCTION MANUAL

Sound Level Meter Unit

UN-14



3-20-41 Higashimotomachi, Kokubunji, Tokyo 185-8533, Japan

<http://www.rion.co.jp/english/>

Organization of this manual

This manual describes the features, operation, and other aspects of the Sound Level Meter Unit UN-14. If the unit is used together with other equipment to configure a measurement system, consult the documentation of all other components as well. The section starting on page iii contains important information about safety. Be sure to read and observe these precautions in full.

This manual contains the following sections.

Outline

Gives basic information about the unit and contains a block diagram.

Names of Parts and Functions

Briefly identifies and explains the front panel display and controls, rear panel connectors and all other parts of the unit.

Linking

Explains how to configure multiple units as a system.

Power Supply Connection

Explains how to make connections for powering the unit.

Microphone Connection

Lists the types of microphones that can be used, and describes how to connect them.

Output Connections

Explains how to use the connectors on the rear panel.

Operation Modes

Explains the operation modes necessary for measurement, including input setup mode, measurement mode, and calibration mode.

Performance Characteristics

Contains charts that show the frequency weighting characteristics, characteristics of the high-pass filter and low-pass filter as well as the influence of extension cables.

Specifications

Lists the technical specifications of the unit.

Reference Material

Provides an explanation of group delay, microphone measurement range, user filters, and maintenance parts.

- * Company names and product names mentioned in this manual are usually trademarks or registered trademarks of their respective owners.

FOR SAFETY

In this manual, important safety instructions are specially marked as shown below. To prevent the risk of severe damage to the unit or peripheral equipment, make sure that all instructions are fully understood and observed.

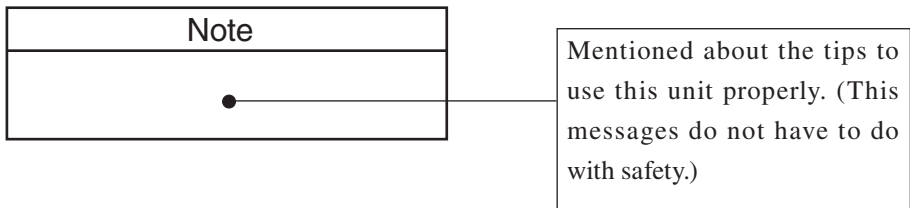
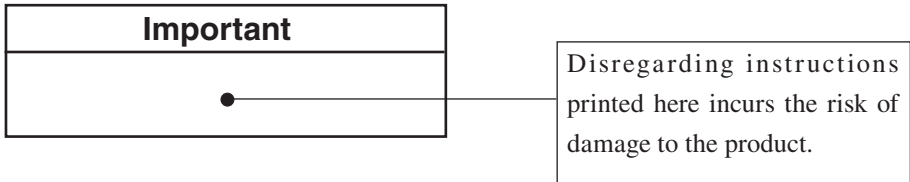
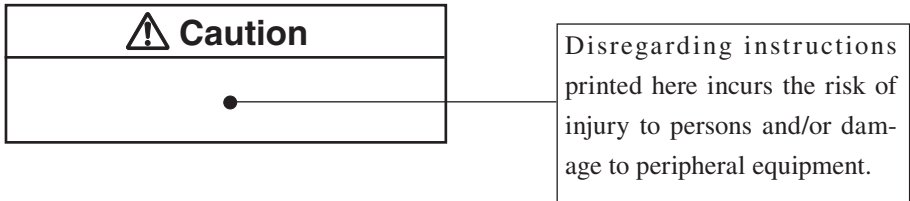

To conform to the EU requirement of the Directive 2002/96/EC on Waste Electrical and Electronic Equipment, the symbol mark on the right is shown on the instrument.



The product described in this manual is in conformity with the following standards;

EN61326:1997+A1:1998+A2:2001+A3:2003

Electrical equipment for measurement control and laboratory use.

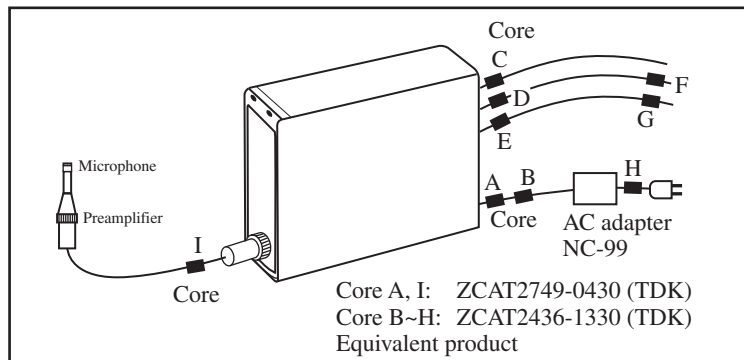

RION Co., Ltd.

3-20-41 Higashimotomachi, Kokubunji, Tokyo 185-8533, Japan

RION Co., Ltd. Europe Representative Office Schaepmanlaan 66, 4623 XZ, Bergen op Zoom, The Netherlands

Precautions

- Operate the unit only as described in this manual.
- Do not disassemble the unit or attempt internal alterations.
- Observe the following precautions before using the unit:
 - Make sure that all connections are properly and safely established.
 - Make sure that the unit is operating normally.
- The permissible ambient temperature range for operation and storage of the unit is -10 to +50°C. Relative humidity must be 90% or below.
- Do not use or store the unit in locations which
 - may be subject to strong magnetic fields or strong radiation, or
 - may be subject to high levels of dust or splashes of water, or
 - may be subject to gases or air with high salt or sulphur content, or are in the vicinity of stored chemicals, or
 - may be subject to high temperature, humidity, or to direct sunlight, or
 - may be subject vibrations or shock.
- Always switch off the power after using the unit.
- When disconnecting cables, always hold the plug or connector and do not pull the cable.
- Use only the specified AC adapter or other specified power source.
- This is a precision device. Take care not to drop the unit and protect it from shocks.
- The LCD panel of the unit can easily become scratched. Do not tap the panel with a pointed object such as a pencil, screwdriver, etc.
- In case of malfunction, do not attempt any repairs. Note the condition of the unit clearly and contact the supplier.
- When disposing of the unit, follow national and local regulations regarding waste disposal.

Contents

FOR SAFETY.....	iii
Precautions.....	v
Outline.....	1
Names of Parts and Functions	4
Front panel	4
Rear panel	6
LCD panel	7
Operation panel	9
Top panel	11
Bottom panel	11
Linking	12
Removing the cable from the link connector	17
Linking with Battery Unit BP-17	18
Using a single UN-14 unit	19
Linking with Interface Unit UV-22	20
Power Supply Connection	21
Using an AC adapter	22
Using the Battery Unit BP-17	23
Microphone Connection	26
Selecting and installing a microphone	26
Possible microphone/preamplifier/ extension cable combinations.....	28
Output Connections	30

Operation Modes	31
Input setup mode	31
Sensitivity setting	32
1) Direct input of sensitivity setting	32
2) Calibration with Sound Calibrator NC-74 or Pistonphone NC-72A	36
3) TEDS communication mode	41
Setting the ID number	42
Measurement setup mode	44
Calibration mode (OUTPUT CAL)	46
Measurement mode	47
Overload indicator LED	48
Bar graph indication	48
Relationship between AC OUT signal voltage and sound pressure level	49
DC OUT signal	50
Check mode	51
Using the Interface Unit UV-22 (option)	52
Factory default settings	54
Performance Characteristics	55
Frequency response characteristics	55
Specifications	57
Reference Material	62
Group Delay	62
Measurement Range	63
User Filter	64
Maintenance parts	66

Outline

The UN-14 is a single-channel sound level meter unit designed for connection of a measurement microphone and preamplifier. The chassis of up to 16 units can be linked to create a multi-channel configuration.

Two types of input connectors are provided (7-pin and BNC), providing support for the following types of microphones and preamplifiers.

- 7-pin connector
Allows connection of Rion microphones (except UC-34P).
Bias voltages of 200 V, 60 V, and 30 V DC are supported.
- BNC connector
Allows connection of CCLD type preamplifiers and microphones.
Power supply specifications are 24 V DC, 4 mA. TEDS is also supported.

Other features of the unit are a backlit LCD panel, alarm LEDs, operation panel, AC and DC output connectors (BNC), DC IN jack, and link connector.

The following accessories are available as options, allowing the configuration of advanced measurement systems suited to various requirements.

- Vibration Meter Unit UV-15
Single-channel vibration meter unit designed for connection of piezo-electric accelerometers.
In combination with the UN-14, a multi-channel sound level and vibration measurement system can be configured.

- **Battery Unit BP-17**

Designed to hold eight IEC R14 (size C) batteries, this unit can be linked to the UN-14 and/or UV-15 to provide power.

The power switch on the front panel of the BP-17 can be used to switch the entire system on and off.

The optional AC adapter NC-97 (for up to 10 units) or NC-99 (for up to 16 units) (CE mark) can be used to provide power.

When powering the system from batteries, the maximum number of units is three.

- **Interface Unit UV-22**

Linking the UV-22 allows connection to a computer for controlling the sound level and vibration measurement system and for transfer of measurement data.

Both USB and Ethernet connections are supported.

UN-14 Block Diagram

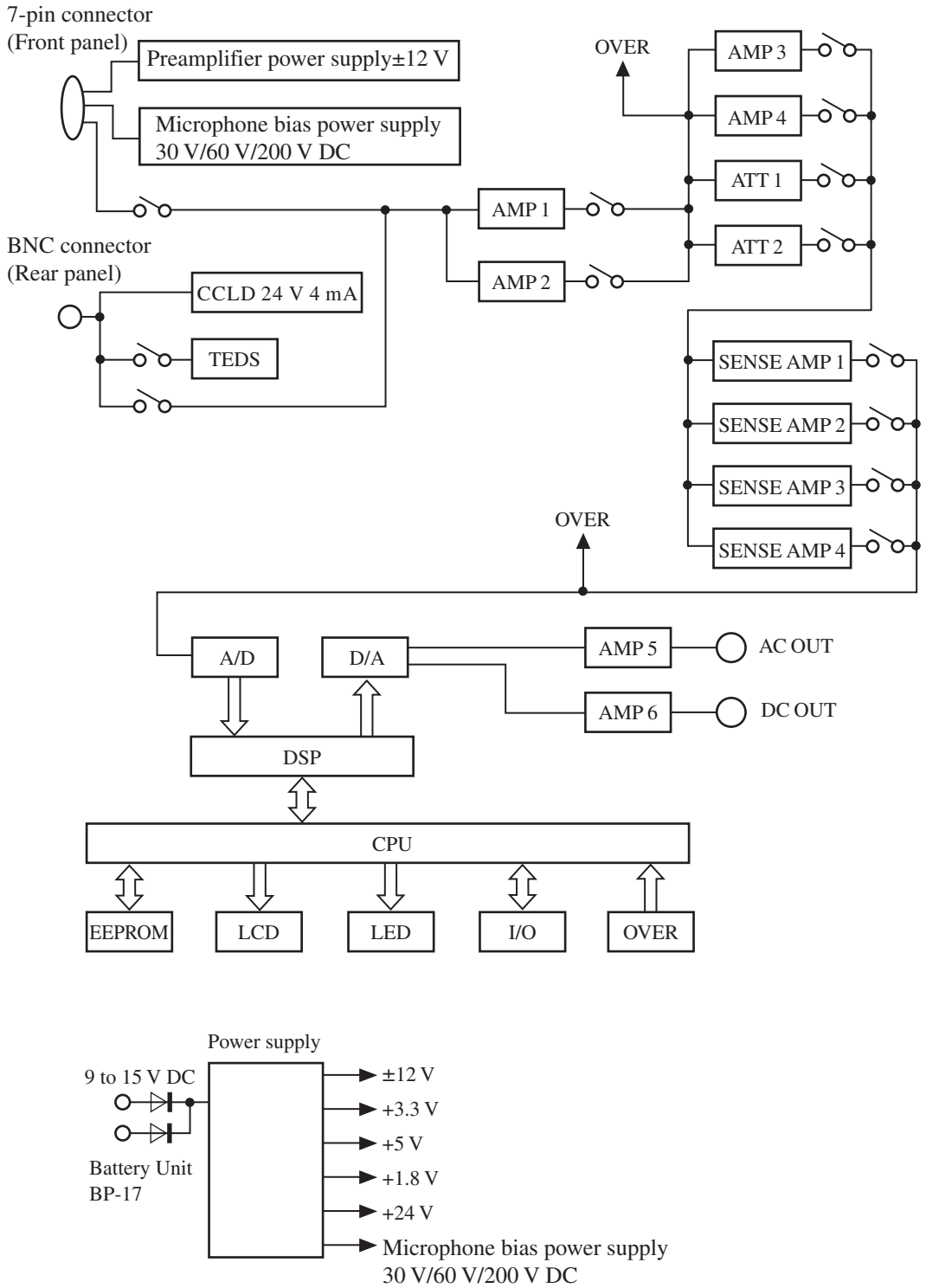

Names of Parts and Functions

Front panel

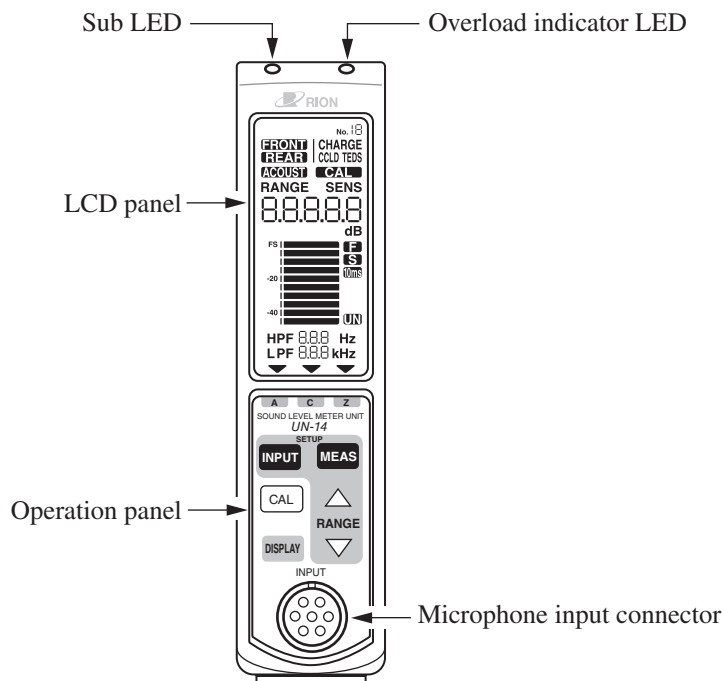

Sub LED

Lights up in green when the Master/Slave function is used.

(The Master/Slave function is available only in conjunction with the UV-22.)

Overload indicator LED

Lights up in red when saturation occurs in the internal amplifier circuitry.

In such a case, correct measurement is not possible.

Microphone input connector

Serves for connection of the microphone/preamplifier. Use an EC-04 series cable for this connection.

Caution

Do not touch the connector pins with wire or similar, because this involves the risk of electric shock.

Operation panel

Control keys for measurement mode (level range selection, display switching etc.) are located here. (For details, see pages 9 to 10.)

LCD panel

Shows setup information, a bar graph display, numeric readout etc.

When the unit is powered from batteries using the Battery Unit BP-17, the display backlight is activated for 10 seconds when any key is pressed.

When the unit is powered from an AC adapter, the display backlight is always on. (For details, see pages 7 to 8.)

Rear panel

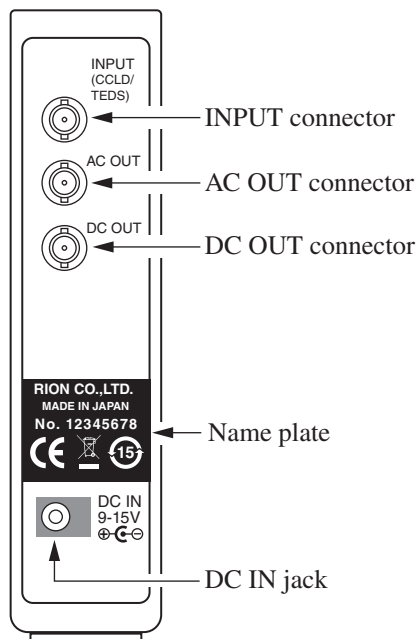

INPUT connector

This connector is designed for connection of a CCLD type preamplifier or microphone. A TEDS compliant preamplifier or microphone can also be connected.

AC OUT connector

Supplies an AC output signal equivalent to the input signal.

DC OUT connector

Supplies a DC output signal equivalent to the input signal.

Name plate

Shows the serial number and other information about the unit.

DC IN jack

Serves for connection of the optional AC adapter or an external DC source.

LCD panel

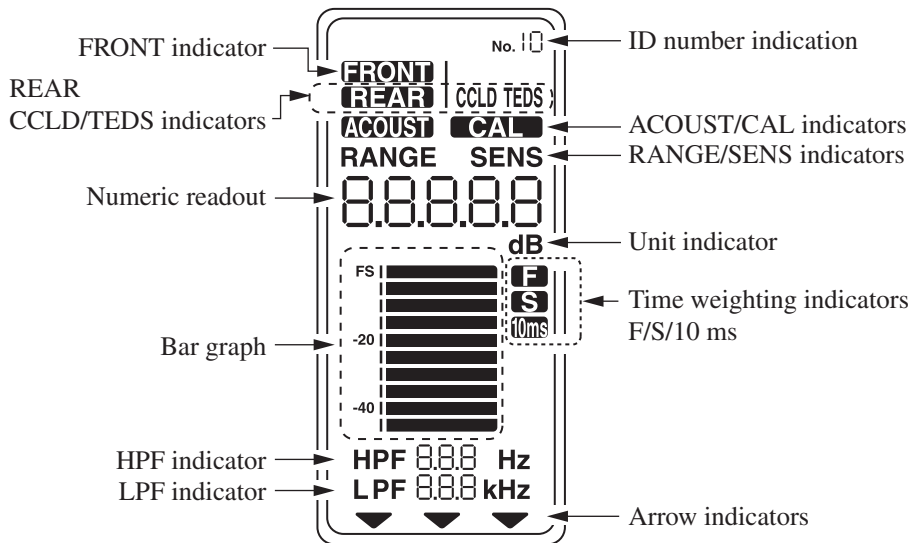

REAR CCLD/TEDS indicators

Show whether REAR CCLD or REAR CCLD TEDS have been selected for the input.

FRONT indicator

Shows whether FRONT has been selected for the input.

ID number indication

Serves to identify the unit in a multi-channel configuration. The number display range is 1 to 16.

ACOUST/CAL indicators

Pressing the CAL key on the operation panel activates the calibration mode (OUTPUT CAL) for calibration of external equipment. Pressing the INPUT key in this condition activates the calibration mode (ACOUST CAL) for acoustic calibration of the microphone. Pressing the CAL key once more returns the unit to the measurement screen.

RANGE/SENS indicators

When the numeric readout shows the level range, the RANGE indicator is on. When the numeric readout shows the sensitivity, the SENS indicator is on. When the numeric readout shows the measurement value, both indicators are off.

Unit indicator

Shows the unit for the measurement value or level range.

Time weighting indicators F/S/10 ms

Show the selected time weighting characteristics.

F: FAST, time constant 125 msec

S: SLOW, time constant 1 sec

10 ms: Time constant 10 msec

Arrow indicators

Below these arrows are labels for the frequency weighting characteristics A, C, and Z. The arrow for the currently selected characteristic is visible.

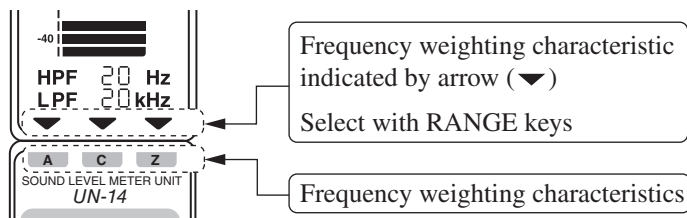

LPF indicator

Shows the selected low-pass filter setting.

HPF indicator

Shows the selected high-pass filter setting.

Bar graph

Shows the level of the signal as a bar graph indication.

Numeric readout

Shows the measurement value, level range, sensitivity, error information, etc.

Measurement value display range: 0.0 to 170.0 dB in 0.1-dB steps

Level range: 70 to 160 dB in 10-dB steps

Sensitivity: -59.9 to -10.0 in 0.1-dB steps

Operation panel

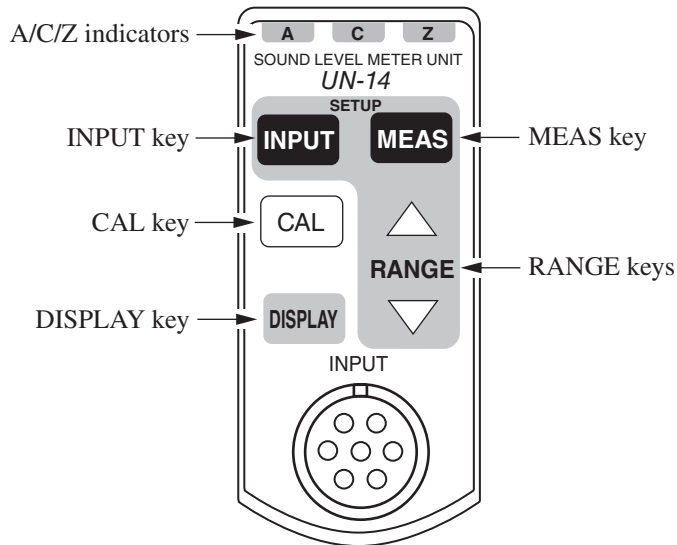

MEAS key

This key serves to select settings for the following input related items.

Time weighting characteristics F/S/10 ms

Frequency weighting characteristics A/C/Z

HPF (High-pass filter) setting

LPF (Low-pass filter) setting

RANGE keys

During measurement, these keys serve to select the level range. In the setup mode, the keys serve to change a setting.

DISPLAY key

During measurement this key serves to switch the numeric readout between range indication and measurement value indication.

CAL key

Pressing this key causes the AC OUT and DC OUT connectors on the rear panel to supply a calibration signal for calibration of external equipment.

Sensitivity calibration using an acoustic calibrator (sound calibrator) in the ACOUST CAL mode is also possible.

INPUT key

Serves to select settings for the following input related items.

Input selection: FRONT or REAR

Start receiving TEDS sensor data

Sensitivity setting

ID number setting

A/C/Z indicators

Show the frequency weighting characteristics selected with the RANGE keys.

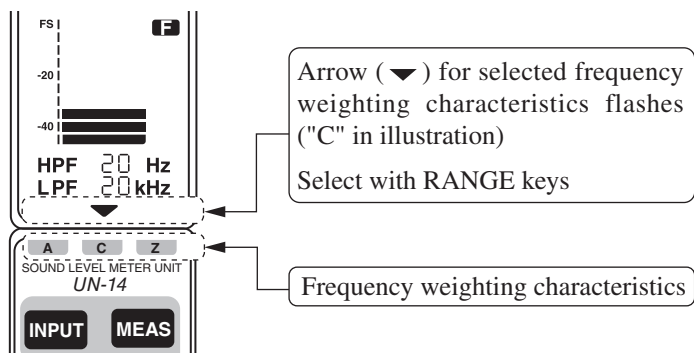

Top panel

The top panel of the unit has two hooks which can be used to join multiple units together.

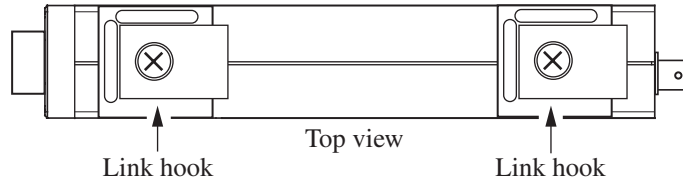

Bottom panel

Removing the cover plates on the bottom of the unit gives access to a connector that is used to supply power when linking multiple units.

Use the supplied link plate to join multiple units.

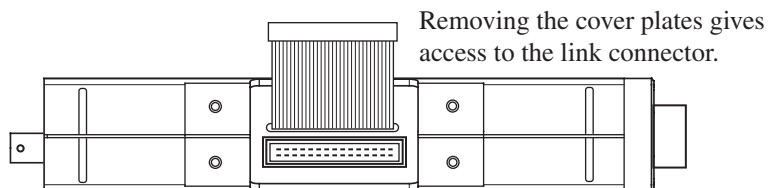
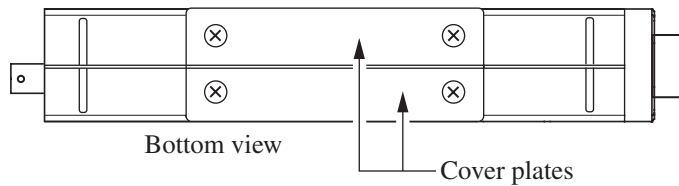

Linking

Multiple UN-14 units can be linked to form a multi-channel system.

The maximum number of units that can be linked is 16. Linking with UV-15 units (option) is also possible.

When using the Battery Unit BP-17 to provide power, the maximum number of units that can be linked is three.

Required tool: 1 Phillips screwdriver (JIS B 4633:1998, type H, No. 2)

Important

Precautions for linking units

- Make sure that power is OFF before starting:
 - Disconnect AC adapter.
 - When using Battery Unit BP-17: Remove batteries
- Do not use any screws other than the ones supplied with the product.
- Do not insert any objects (pieces of metal, pencil lead, etc.) into the unit.
- Use only the specified screwdriver (Phillips screwdriver, JIS B 4633:1998, type H, No. 2). Otherwise the cross-shaped slots on the screw heads may be damaged.

Linking procedure

1. Remove the 4 screws holding the cover plates on the bottom of the unit, and remove the cover plates.

Put the screws and cover plates in a box or other suitable container, to make sure that you do not lose any parts. The parts will be required later for reassembly.

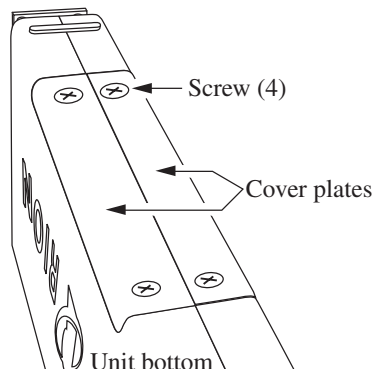

2. Remove the two link hooks on the top panel. Do not remove these hooks for the unit that will be the rightmost unit as seen from the front.

Put the screws and hooks in a box or other suitable container, to make sure that you do not lose any parts. The parts will be required later for reassembly.

Remove link hooks and fastening screws
on other units

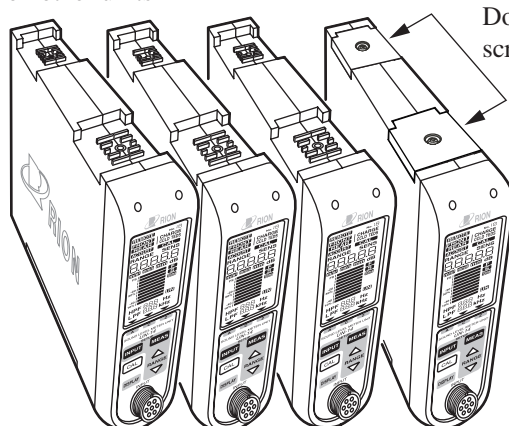

Do not remove hooks and fastening
screws of rightmost unit

3. For the leftmost unit as seen from the front, roll up the link cable around the connector and push it into the empty space in the unit.

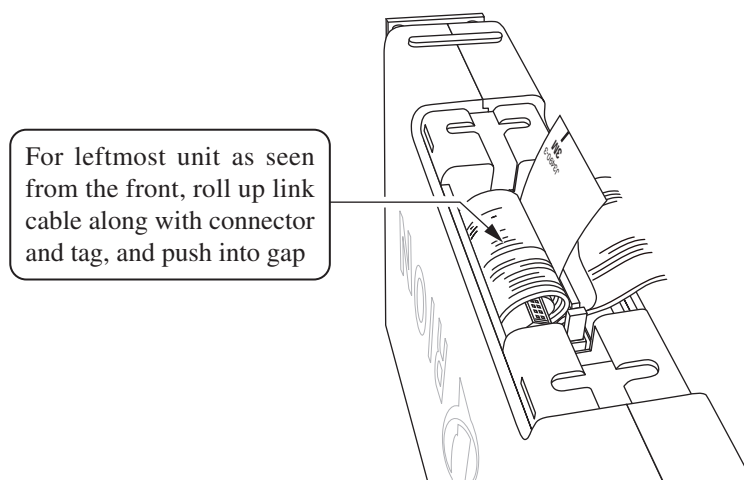

4. Plug the link connector of each unit into the next unit.

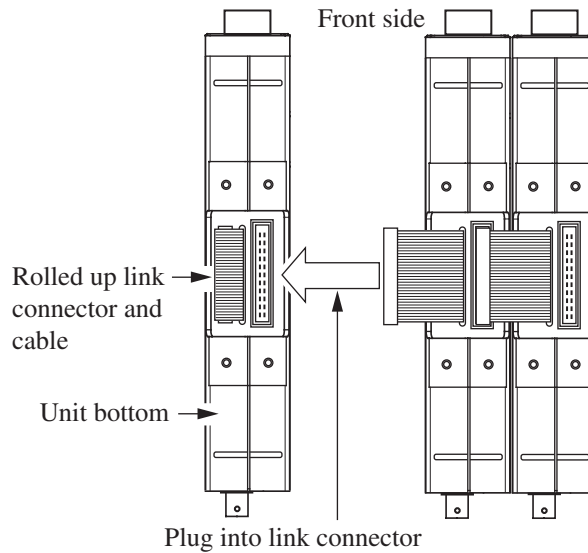

5. After plugging in the link connectors, use the supplied link plates and screws to provisionally join the units as shown below.

Use the screws removed in step 1.

Why not to use other screws:

Too short screws will not properly secure the plate.

Too long screws may damage parts inside the unit.

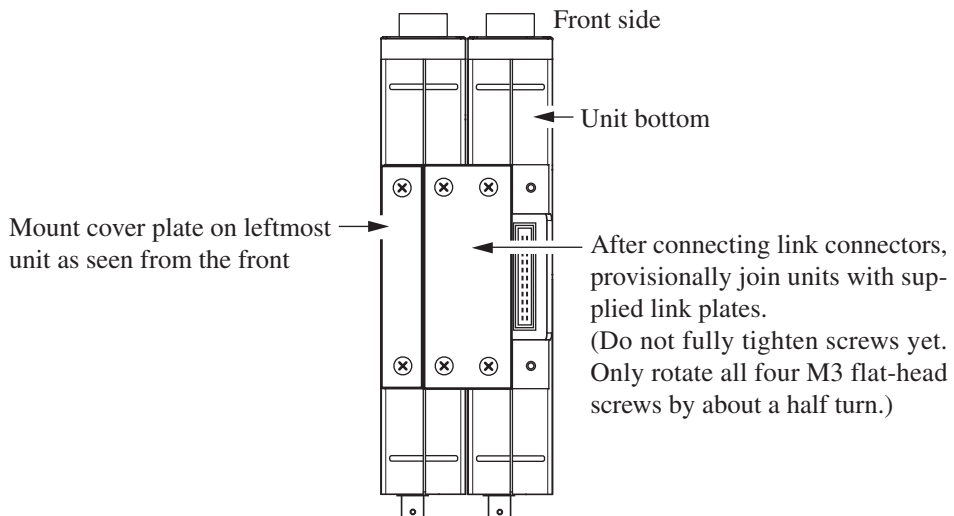

- Attach the link hooks removed in step 2 to the unit tops, so that the units are locked together.

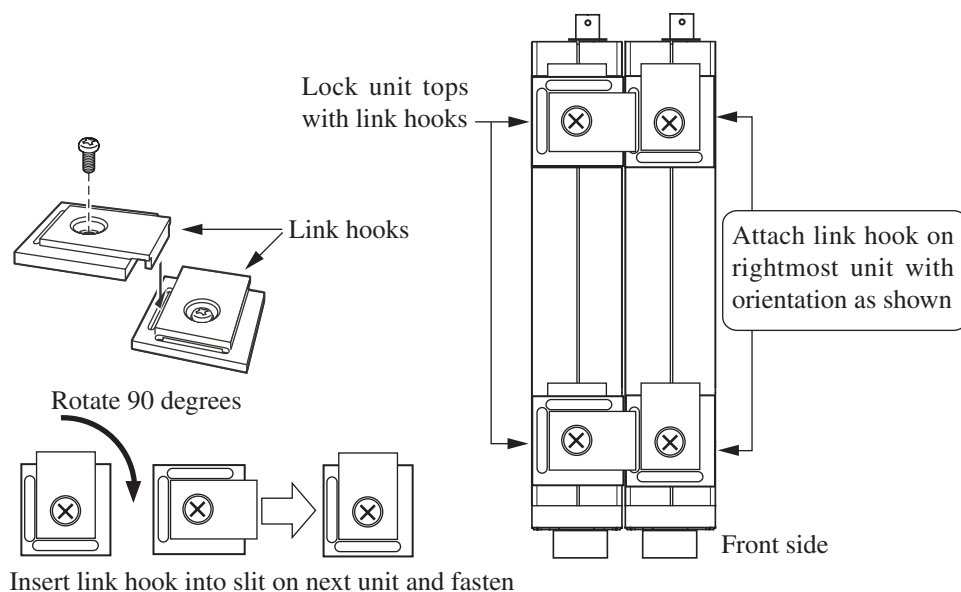

- Make sure that all link connectors are plugged in, and sequentially link the units with the supplied link plates.

Attach the cover plates to the leftmost and rightmost unit.

Securely tighten all flat-head screws.

Use the screws removed in step 1 to fasten the plates.

Why not to use other screws:

Too short screws will not properly secure the plate.

Too long screws may damage parts inside the unit.

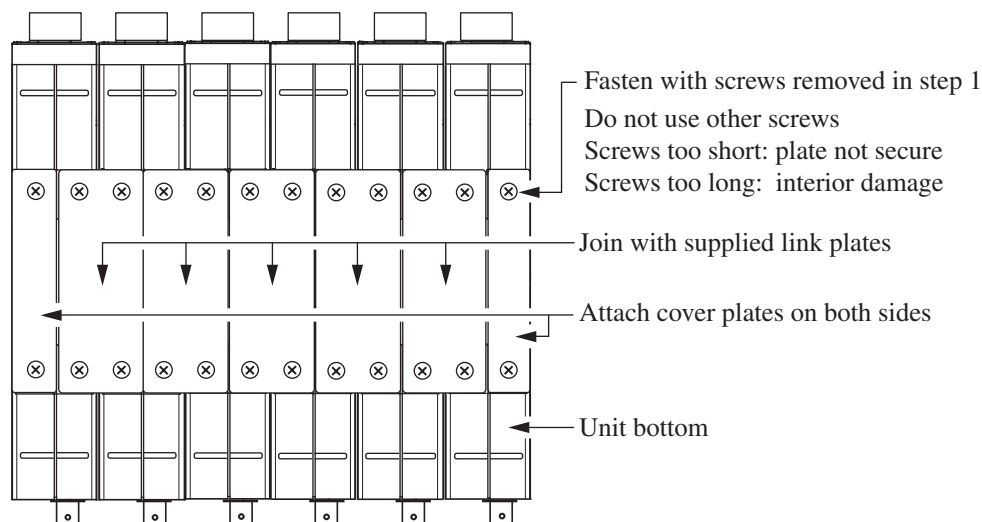

- Attach the link hooks to the unit tops, so that the units are locked together.

Securely tighten all screws.

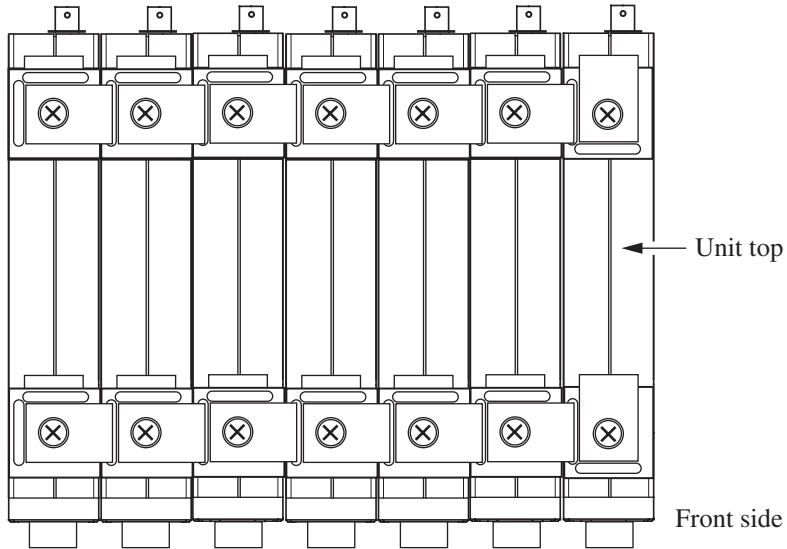

Note

If you have lost the original screws, refer to the information about maintenance parts on page 66. Commercially available screws can also be used, provided that exact specifications are met.

Fastening screw for link hook on unit top

Truss-head screw M4 × 8 (screw length 8 mm)

Fastening screw for link plate on unit bottom

Flat-head screw M3 × 10 (screw length 10 mm)

Screw types listed according to JIS B 1111.

Removing the cable from the link connector

To unplug the link connector, grasp the tag as shown in the illustration below and carefully pull the connector out.

Important

Be sure to grasp the side with the "3M" lettering. If you pull on the other side, the tag may break.

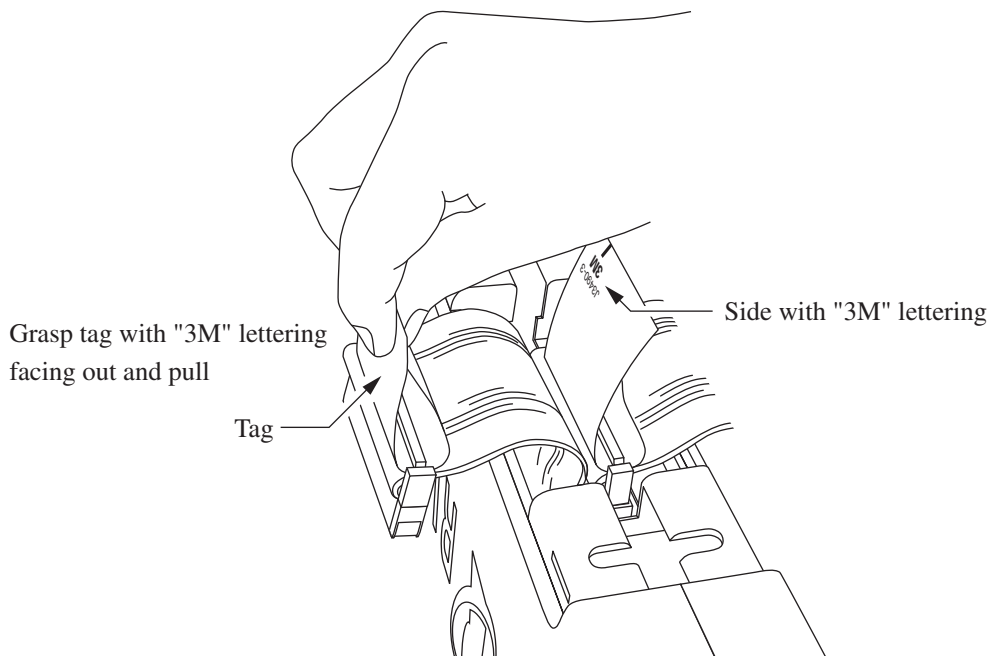

Linking with Battery Unit BP-17

Install the Battery Unit BP-17 as the rightmost unit of the system as seen from the front.

The cover of the battery compartment in the Battery Unit BP-17 is located on the right side. When installed in this way, the cover can be opened to access the compartment and insert/remove batteries.

Sound Level Meter Unit UN-14 (up to three units when powered by batteries)

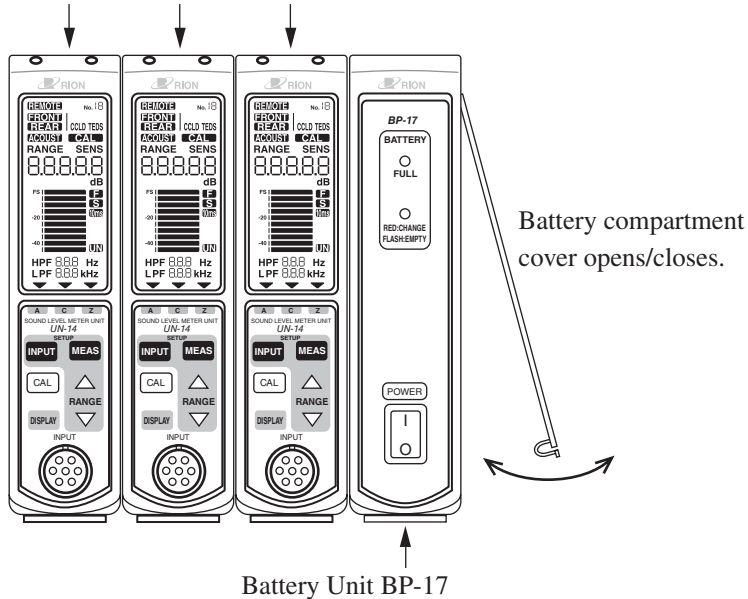

Note

The AC adapter NC-97 can power up to 10 linked units and the AC adapter NC-99 up to 16 linked units.

Using a single UN-14 unit

Attach the supplied link plate to the bottom of the unit as shown below, to stabilize the unit when it is used in a free-standing configuration.

Use the screws removed from the unit.

Why not to use other screws:

Too short screws will not properly secure the plate.

Too long screws may damage parts inside the unit.

1. Remove two screws from the cover plates on the bottom of the unit (the two screws that are nearer to the front side). Refer to the left-side illustration (Fig. 1) below.
2. Use the screws removed in step 1 to fasten the supplied link plate sideways. Refer to the right-side illustration (Fig. 2) below.

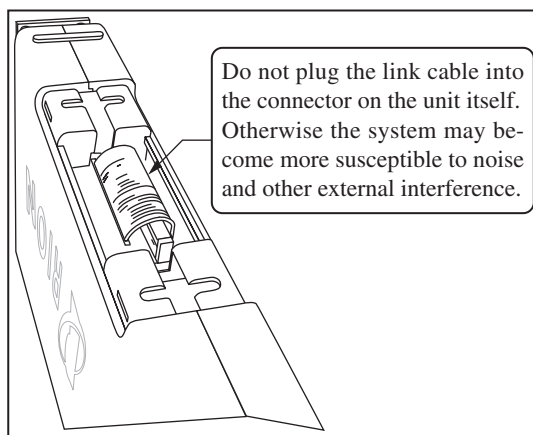
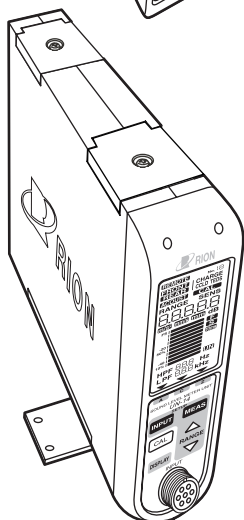
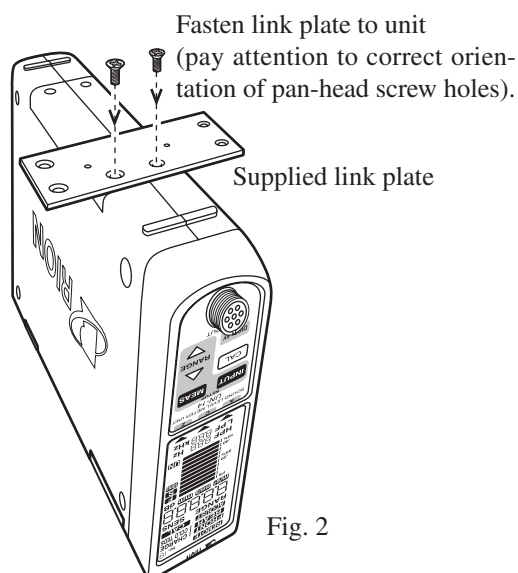
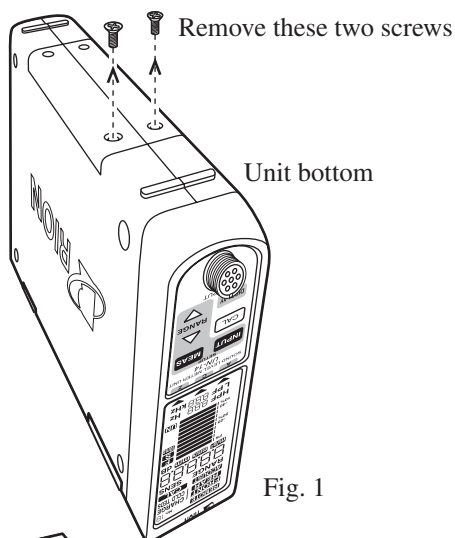

Linking with Interface Unit UV-22

Install the Interface Unit UV-22 as the leftmost unit as seen from the front.

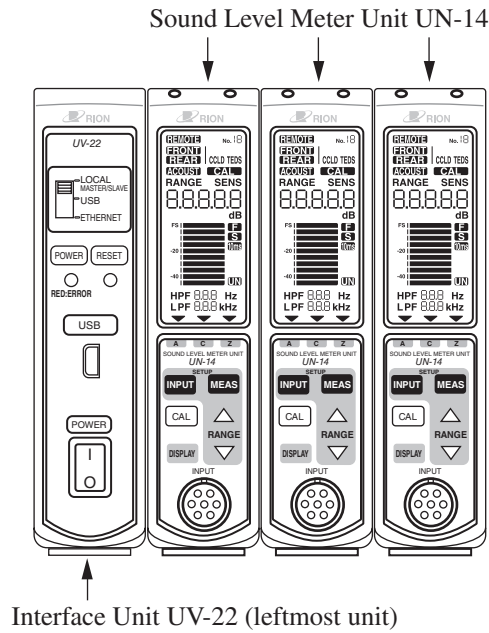

Power Supply Connection

The UN-14 can be powered from an AC adapter (option), the Battery Unit BP-17 (option), or a car battery (12 V).

The UN-14 does not have a power switch. It will start to operate when power is supplied.

The Battery Unit BP-17 (option) and Interface Unit UV-22 (option) have a power switch which allows shutting down the system.

Important

When using multiple units in a linked configuration, make sure that system assembly is fully completed before supplying power.

Power supply limitations		
Power supply type	Max. number of units	
AC adapter (option)	NC-97	Up to 10 units and one UV-22
	NC-99 (CE mark)	Up to 16 units and one UV-22
Battery Unit BP-17 (option)	IEC R14 (size C) battery × 8	Up to 3 units and one UV-22

Note

The display backlight is always on when the unit is powered from an AC adapter. When the unit is powered from batteries using the Battery Unit BP-17, the display backlight is activated for 10 seconds when any key is pressed.

If a system which includes the UN-14 and the Battery Unit BP-17 is to be powered by an AC adapter, be sure to connect the AC adapter to the BP-17.

The UN-14 does not have a power switch. It will start to operate when power is supplied.

Using an AC adapter

⚠ Caution

Be sure to use only a single AC adapter to power a linked system consisting of multiple UN-14 Sound Level Meter Units.

Important

Do not use any AC adapter other than the specified models. Otherwise malfunction and damage may occur.

If no Battery Unit BP-17 or Interface Unit UV-22 is installed in the system, the AC adapter may be connected to any UN-14 unit.

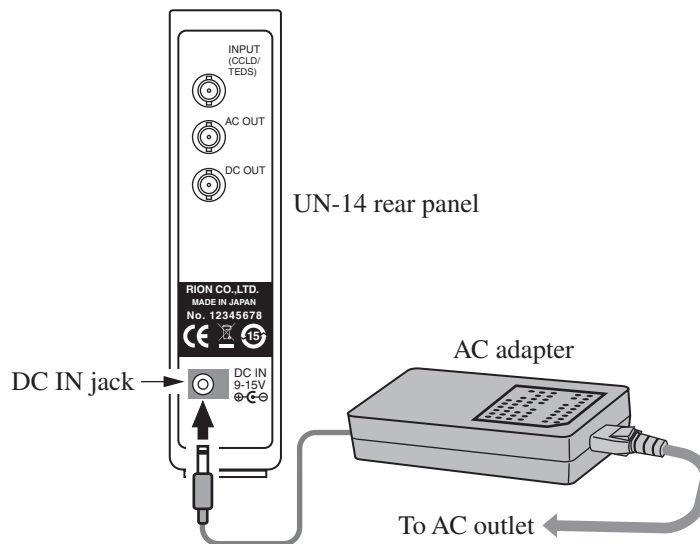

Note

If the system includes an Interface Unit UV-22 but no Battery Unit BP-17, connect the AC adapter to the UV-22.

Using the Battery Unit BP-17

Battery life

Figures for approximate battery life when using the Battery Unit BP-17 are given below.

These figures are for using three UN-14 units.

Manganese batteries	Approx. 1.5 hours
Alkaline batteries	Approx. 6 hours

Continuous operation at ambient temperature of 25°C, with FRONT setting, normal operation mode

When using manganese batteries, pay attention to battery life.

For details on how to insert batteries and for other information, please refer to the documentation of the BP-17.

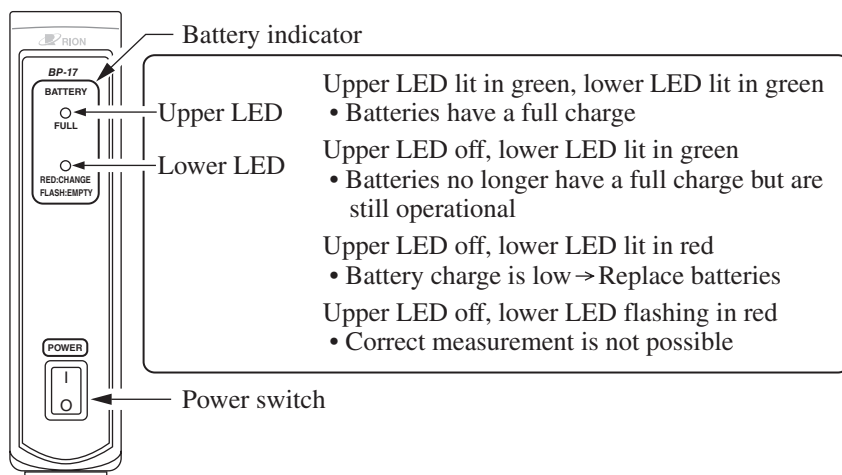

Battery Unit BP-17

Important
When the upper LED is off and the lower LED lights up in red, you should replace the batteries with a fresh set.
When the lower LED is flashing in red, correct measurement is no longer possible.
Before replacing the batteries, be sure to set the power switch to OFF (press O side).
When inserting batteries, take care not to mix up "+" and "-" polarity.
Always replace all eight batteries together. Using a mixture of old and new batteries or batteries of a different type can lead to malfunction and damage.
When not using the unit, remove the batteries to guard against the risk of damage by leaking battery fluid.
When powering a system from batteries using the BP-17, the maximum number of UN-14 units that can be linked is three.

The Battery Unit BP-17 has a DC IN jack on the rear panel. To power the system from an optional AC adapter, connect the adapter to this jack.

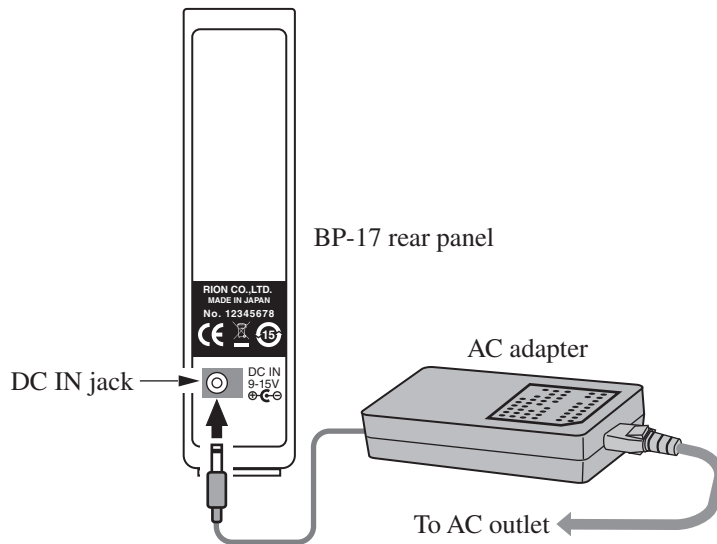

Important

Do not use any AC adapter other than the specified models. Otherwise malfunction and damage may occur.

If the unit is powered from the AC adapter, continued operation during a power failure is not assured.

Note

The Battery Unit BP-17 does not have a charging function.

If a system which includes the UN-14 and the Battery Unit BP-17 is to be powered by an AC adapter, be sure to connect the AC adapter to the BP-17.

Microphone Connection

Selecting and installing a microphone

In a regular configuration, connect the microphone to the preamplifier, the preamplifier to the extension cable, and the extension cable to the UN-14. The UN-14 has is equipped with an input connector on the front panel and one on the rear panel. For details on the combination of microphone, preamplifier, and extension cable, see page 28.

Input	Connector type	Preamplifier power supply	TEDS
Front panel	7-pin connector	± 12 V DC Microphone bias voltage 200 V, 60 V, 30 V DC	Not supported
Rear panel	BNC connector	24 V DC, 4 mA	Supported

Using the front panel microphone input connector

A connection example is shown below.

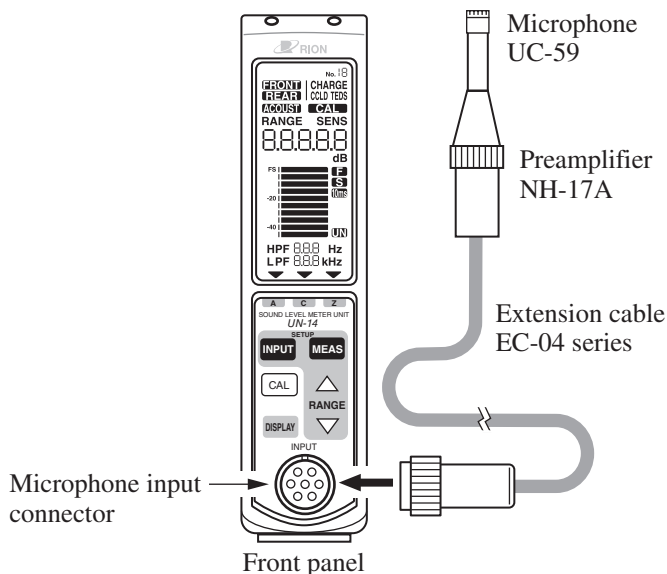

⚠ Caution

Do not touch the connector pins with wire or similar, because this involves the risk of electric shock.

Microphone input connector wiring diagram

The pinout of the microphone input connector is shown below.

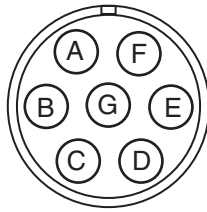

- A: Preamplifier power supply output (+12 V)
- B: Ground
- C: Signal input
- D: Preamplifier power supply output (-12 V)
- E: Bias voltage output (30 V)
- F: Bias voltage output (60 V)
- G: Bias voltage output (200 V)

Using the rear panel input connector

Make the connection as shown below.

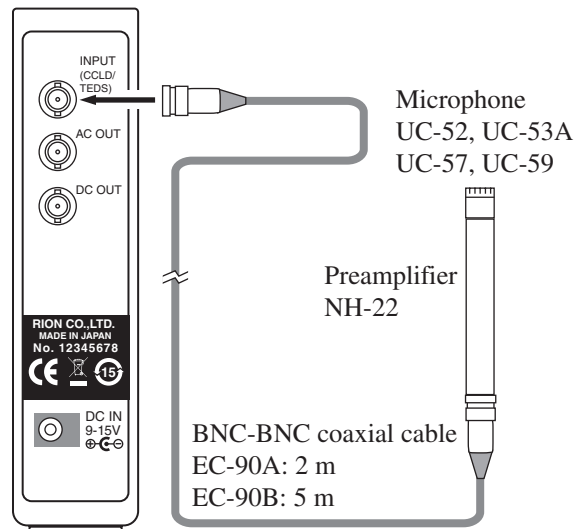

Note

When connecting a TEDS compliant sensor, the allowable cable length for TEDS communication should be 20 meters or less on the condition as follows.

Preamplifier:	NH-22T
Cable:	EC-90 or equivalent 3C-2V

Possible microphone/preamplifier/extension cable combinations

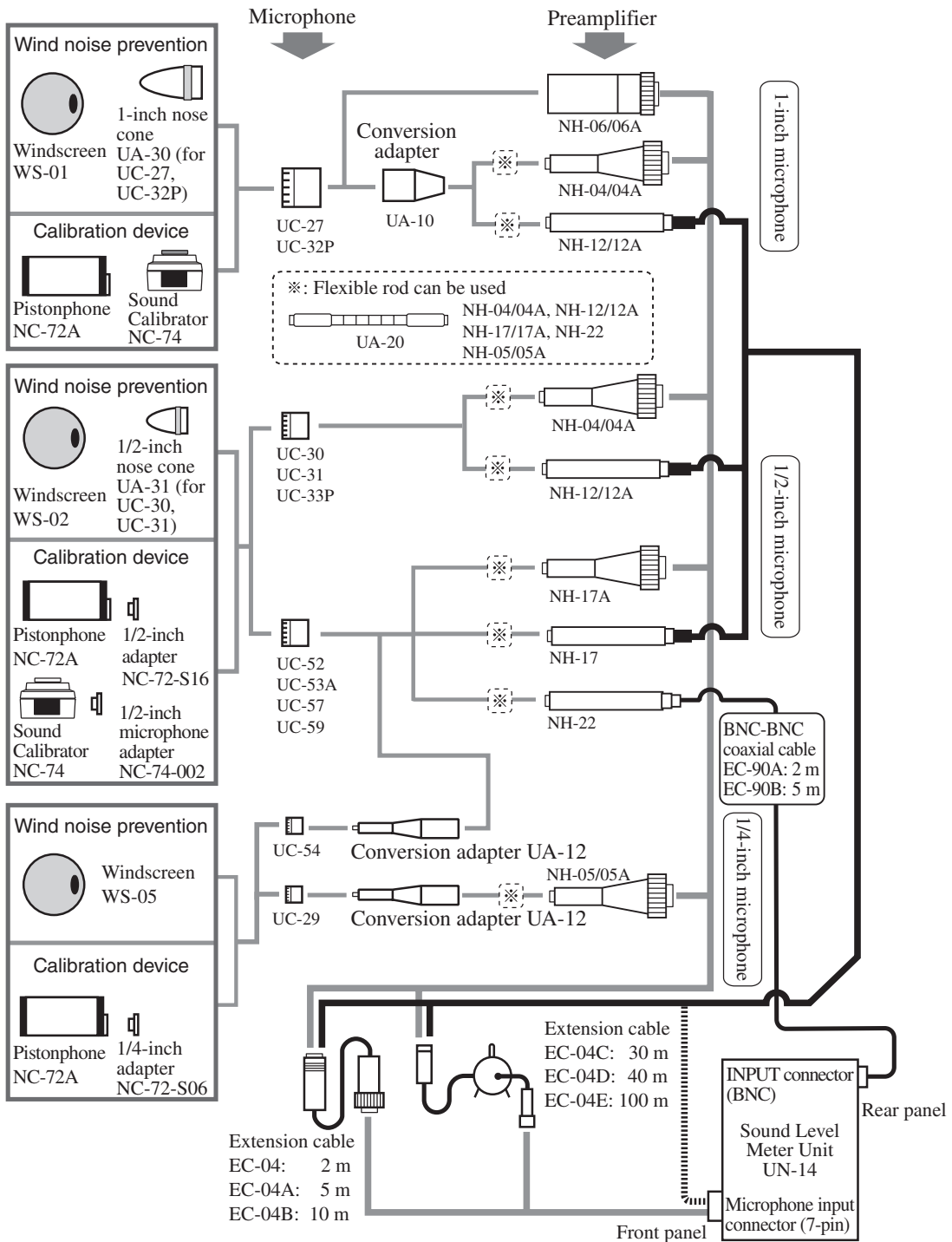

To use a microphone tripod, fasten the microphone holder supplied with the extension cable to the tripod, and plug the connector of the extension cable into the microphone holder.

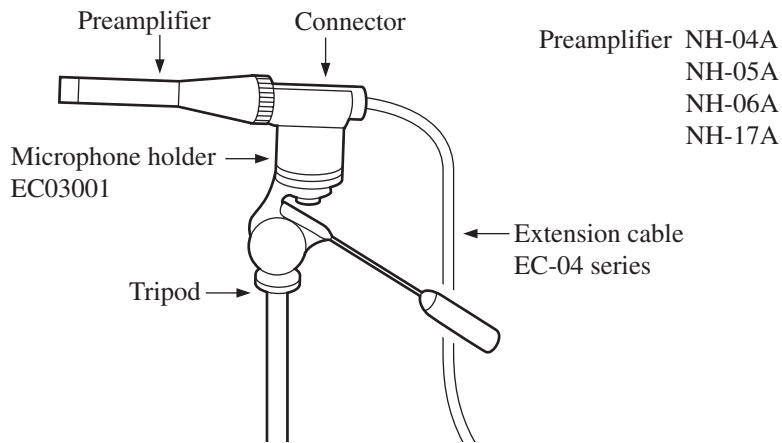

To use the preamplifier NH-12A, NH-17, or NH-22, plug the preamplifier into the 1/2-inch microphone holder UA-90 (option).

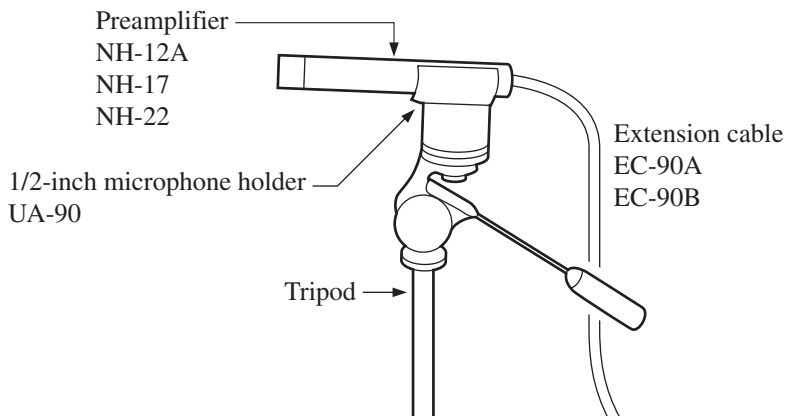

Output Connections

The rear panel of the UN-14 provides one AC output connector and one DC output connector. These can be used to supply a signal for example to an oscilloscope for waveform observation, to a data recorder for recording, or to an FFT analyzer for analysis. The calibration signal (see page 46) is also output from these connectors.

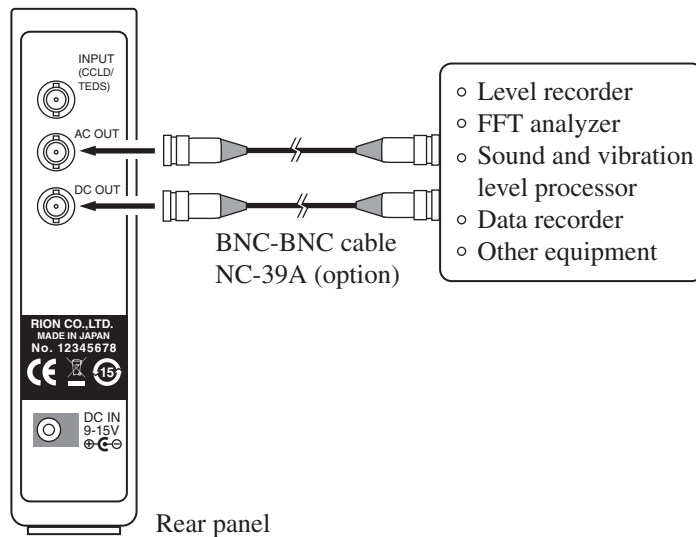

Output type	AC OUT	DC OUT
Connector type	BNC	BNC
Output impedance	Approx. 600 Ω	Approx. 50 Ω
Output voltage at range full-scale point	1 V (rms)	+3.5 V
Max. output voltage	Approx. ± 5 V (peak) (no-load condition)	Approx. +5 V (no-load condition)
Load impedance	10 k Ω or higher	10 k Ω or higher

Operation Modes

The unit has the following operation modes.

Operation mode	Function outline
Input setup mode	Make settings for input (connector, sensitivity) and ID number
TEDS communication mode	Receive sensitivity data and other information from TEDS compliant microphones
Measurement setup mode	Make settings for frequency weighting, time weighting, HPF, and LPF
Calibration mode	<p>OUTPUT CAL: Supply calibration signal for calibration of external equipment</p> <p>ACOUSTIC CAL: Use sound calibrator to set sensitivity of UN-14 and calibrate external equipment</p>
UV-22 communication mode	Control UN-14 from connected Interface Unit UV-22
Measurement mode	Make measurements
Check mode	Check software version of UN-14

Input setup mode

This serves to make settings for the connected microphone and preamplifier and select an ID number for the UN-14. Be sure to make or check these settings before starting a measurement.

Input setup mode functions	
Item	Settings
Input connector selection	FRONT REAR CCLD REAR CCLD TEDS
Sensitivity selection	-59.9 to -10.0 dB/Pa in 0.1-dB/Pa steps
ID number selection	1 to 16 in 1 step

Sensitivity setting

Before starting a measurement, you must set the sensitivity to match the microphone and preamplifier in use.

There are three ways to set the sensitivity:

- 1) Directly input the sensitivity value.
- 2) Use the Sound Calibrator NC-74 (option) or Pistonphone NC-72A (option) to set the sensitivity.
- 3) Use a TEDS compliant sensor and obtain the setting by TEDS communication.

1) Direct input of sensitivity setting

1. Pressing the INPUT key in measurement mode activates the input setup mode.

Make the setting according to the microphone and preamplifier that are being used.

FRONT: Microphone input connector on front panel is used

REAR CCLD: Input connector on rear panel is used

Note

To directly input the sensitivity for a TEDS compliant microphone, select REAR CCLD for the input setting.

Use the RANGE keys to change and select the setting.

Press the INPUT key when the setting has been made.

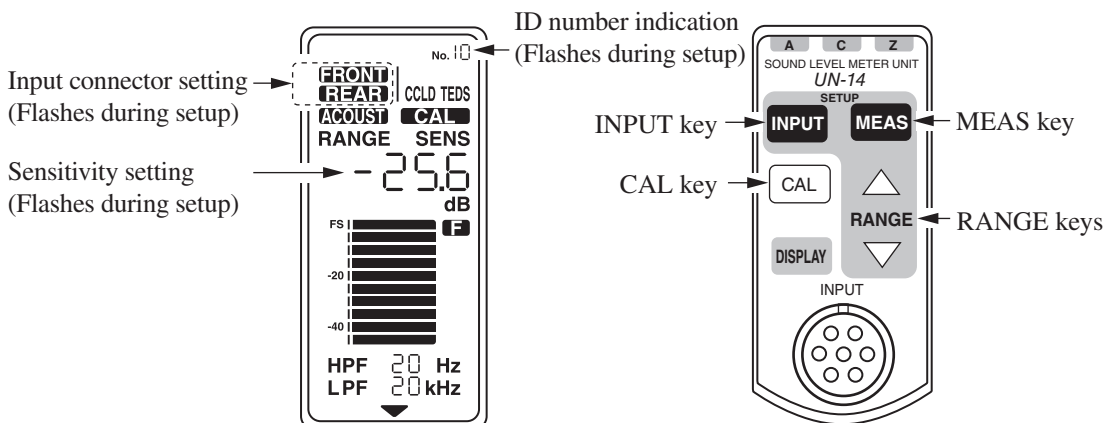

- When you press the INPUT key, the unit switches to the sensitivity setting screen.

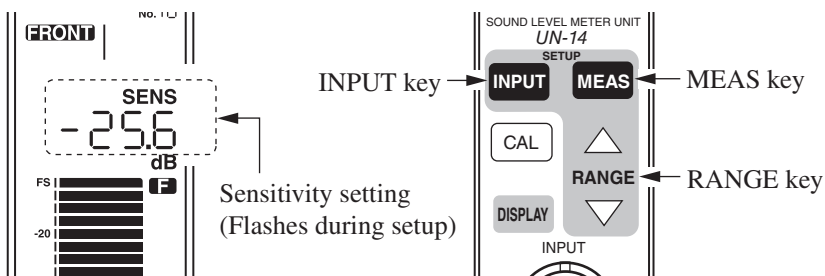

- Use the RANGE (Δ / ∇) keys to set the indicated value as required (microphone sensitivity + preamplifier loss). Holding down a RANGE key changes the numeric value more quickly.

For information on the microphone sensitivity value, refer to the calibration chart supplied with the microphone.

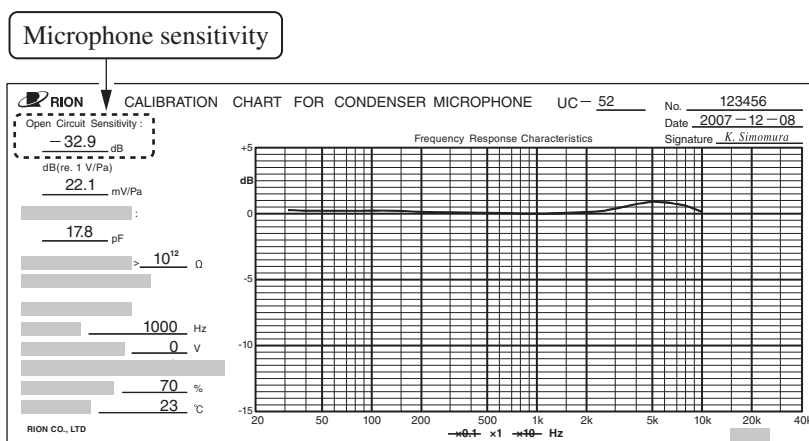

Calibration chart (example)

The preamplifier loss (loss caused by microphone capacitance and preamplifier capacitance) can be determined from the chart below, according to the equipment combination.

Microphone Preamplifier	1-inch	1/2-inch					1/4-inch	
	UC-27 UC-32P	UC-30 UC-31 UC-33P	UC-52	UC-53A	UC-57	UC-59	UC-54	UC-29
NH-04, NH-12	---	-0.4	---	---	---	---	---	---
NH-04A, NH-12A	---	-0.2	---	---	---	---	---	---
NH-05	---	---	---	---	---	---	---	-0.9*
NH-05A	---	---	---	---	---	---	---	-0.5*
NH-06	-0.3	---	---	---	---	---	---	---
NH-06A	-0.1	---	---	---	---	---	---	---
NH-17, NH-17A	---	---	-0.4	-0.6	-0.5	-0.6	-2.0**	---
NH-22	---	---	-0.5	-0.6	-0.6	-0.6	-2.0**	---

* : Using 1/4-inch to 1/2-inch conversion adapter UA-12

Unit: dB

Example

Combination of 1/2-inch condenser microphone UC-52 (sensitivity -32.9 dB) and preamplifier NH-17A (loss -0.4 dB)

$$(-32.9) + (-0.4) = -33.3$$

Consequently, the sensitivity value to enter is "-33.3".

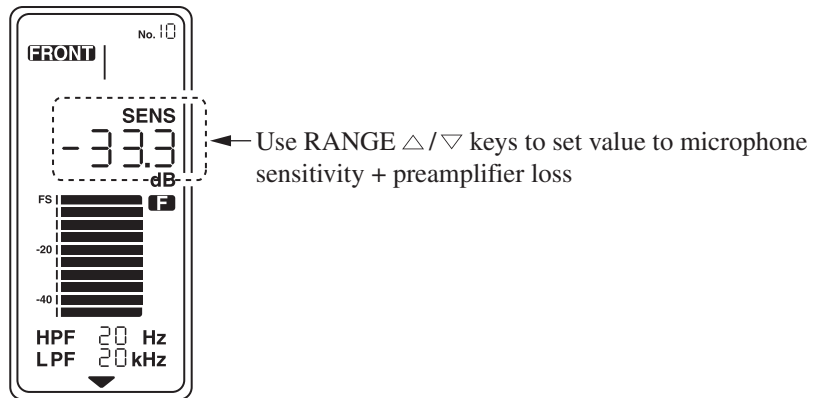

4. When the setting is as required, press the INPUT key.
5. Press the MEAS key to return to the measurement mode.

2) Calibration with Sound Calibrator NC-74 or Pistonphone NC-72A

This section describes the procedure for mounting the Sound Calibrator NC-74 or Pistonphone NC-72A on the microphone and performing acoustic calibration by matching the indicated level to the sound pressure level inside the coupler.

Important
Insert the microphone into the Sound Calibrator NC-74 or Pistonphone NC-72A very slowly and carefully, because the pressure change could otherwise damage the diaphragm of the microphone.

1. Turn power to the Sound Calibrator NC-74 or Pistonphone NC-72A off.
2. With the unit in measurement mode, select the measurement range. When using the Sound Calibrator NC-74, set the level range to 100. When using the Pistonphone NC-72A, set the level range to 120.

If the sensitivity is set to a value from -50.0 to -59.9, the level range cannot be set to 100. Set the sensitivity to a value from -10.0 to -49.9 for calibration.

3. Use measurement setup mode (see page 44) to set the frequency weighting characteristics to C.
4. With the unit in measurement mode, press the CAL key. When you press the CAL key, the unit switches to OUTPUT CAL mode.
5. With the unit in OUTPUT CAL mode, press the INPUT key. The unit switches to ACOUSTIC CAL mode.

6. Turn power to the Sound Calibrator NC-74 or Pistonphone NC-72A on.

While the microphone is exposed to the acoustic signal, perform sensitivity calibration. To set the sensitivity value, use the RANGE keys.

7. When the sound pressure level of the Sound Calibrator NC-74 or Pistonphone NC-72A is the same as the measurement value at the UN-14, the setting is completed. Press the INPUT key to return to the OUTPUT CAL mode, and press the CAL key to return to the measurement mode.

For details on using the Sound Calibrator NC-74 or Pistonphone NC-72A, refer to the documentation of the respective product.

Note

In CAL mode, time weighting characteristics is set to F and HPF and LPF are set to OFF.

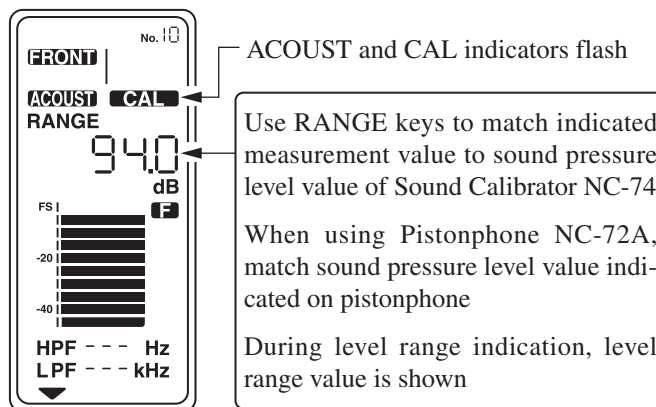

To perform calibration using a 1/2-inch condenser microphone, mount the 1/2-inch adapter on the coupler of the Sound Calibrator NC-74 or Pistonphone NC-72A.

The adapter is not required when using a 1-inch condenser microphone.

1/2-inch adapter for NC-74
NC-74-002

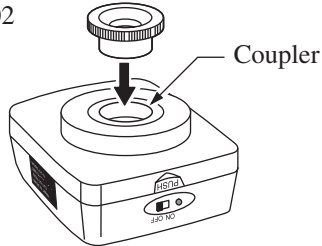

Sound Calibrator NC-74

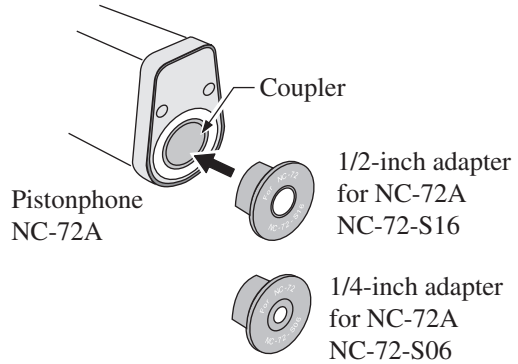

Pistonphone
NC-72A

1/2-inch adapter
for NC-72A
NC-72-S16

1/4-inch adapter
for NC-72A
NC-72-S06

Note

When using a 1/4-inch condenser microphone, mount the 1/4-inch adapter on the Pistonphone NC-72A. There is no 1/4-inch adapter for the Sound Calibrator NC-74.

The calibration values for the Sound Calibrator NC-74 are listed in the table below.

Nominal diameter	Microphone model	Calibration value (dB)
1-inch	UC-11	93.8
	UC-25	93.5
	UC-27	93.8
	UC-34	93.8
1/2-inch	UC-26	93.9
	UC-30	94.0
	UC-31	93.9
	UC-52	93.9
	UC-53A	94.0
	UC-57	94.1
	UC-59	94.0

With the Pistonphone NC-72A, use the output sound pressure value as marked on the unit.

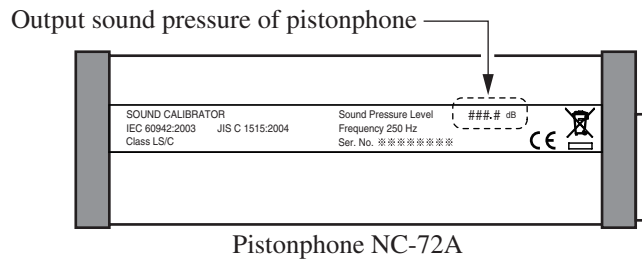

Note

For details on using the Sound Calibrator NC-74 or Pistonphone NC-72A, refer to the documentation of the respective product.

Information about atmospheric pressure compensation is provided in the documentation of the Pistonphone NC-72A.

The Sound Calibrator NC-74 is designed and manufactured to produce a sound pressure level of 94.0 dB under the rated conditions. However, in actual use, the sound field compensation value and other factors when performing sensitivity calibration require a different calibration value for different models.

Use the value listed in the table below, according to the microphone that is being used.

Nominal diameter	Microphone model	Calibration value (dB)
1-inch	UC-11	93.8
	UC-25	93.5
	UC-27	93.8
	UC-34	93.8
1/2-inch	UC-26	93.9
	UC-30	94.0
	UC-31	93.9
	UC-52	93.9
	UC-53A	94.0
	UC-57	94.1
	UC-59	94.0

3) TEDS communication mode

In this mode, the UN-14 communicates with the TEDS sensor to receive sensitivity information and set the sensitivity accordingly.

TEDS communication can be carried out in the input setup mode. If a TEDS sensor was used previously, TEDS communication will also be carried out when power is supplied the next time.

1. Pressing the INPUT key in measurement mode activates the input setup mode.
2. Use the RANGE keys to select REAR CCLD TEDS.
3. Press the INPUT key to start communication with the TEDS sensor.
4. When TEDS communication is completed, the sensitivity will be automatically set, and the screen for setting the ID number appears.

TEDS sensor support: IEEE1451.4-2000 Template ID: 12,27,28

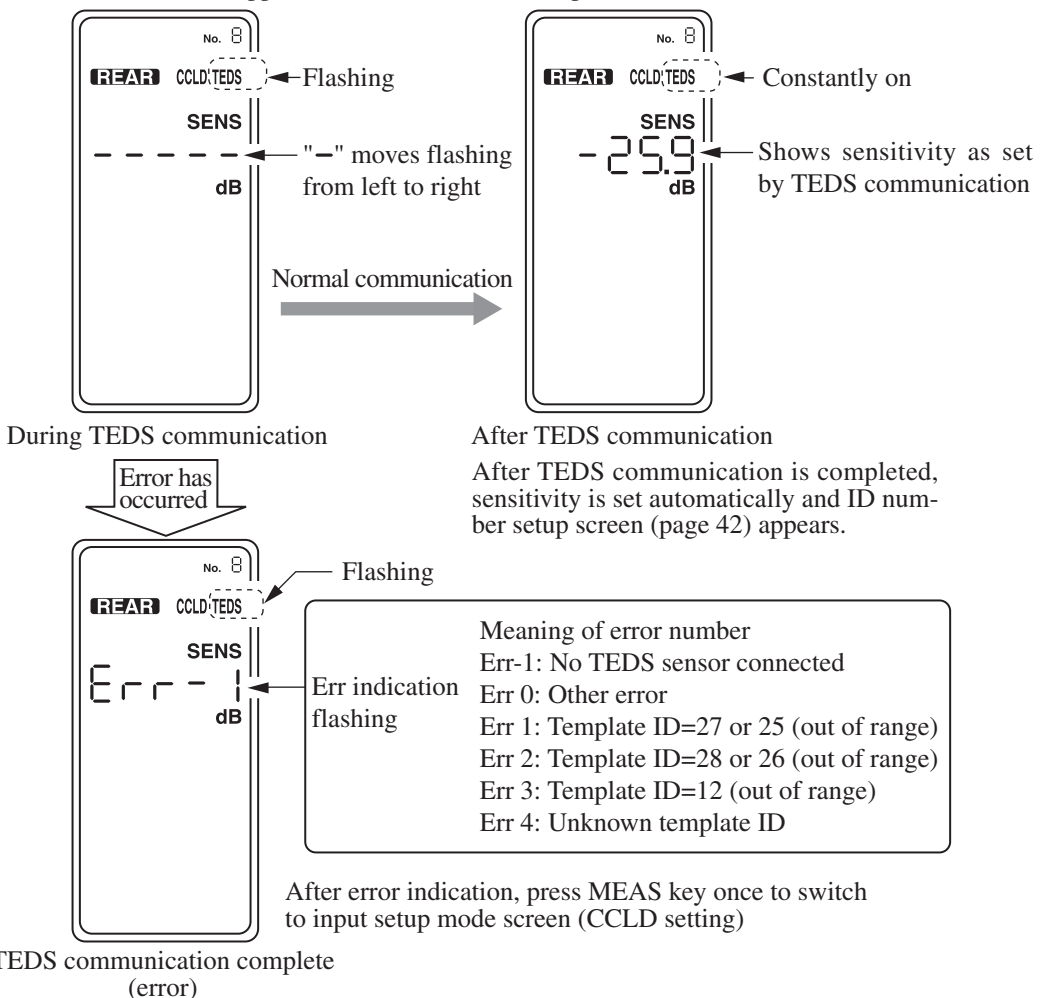

Setting the ID number

When the UN-14 is used in conjunction with the Interface Unit UV-22, an ID number for the UN-14 must be set first.

To set the ID number, the keys on the operational panel of the respective UN-14 unit must be used.

The default setting for the ID number is No. 1. Be sure to change the setting when there is more than one unit. The setting range is No. 1 to No. 16.

The ID number is used to identify the unit for communication. If there is more than one unit in the same system with the same ID number, correct communication will not be possible. When UV-15 units are linked, these must also have unique ID numbers.

See illustration below

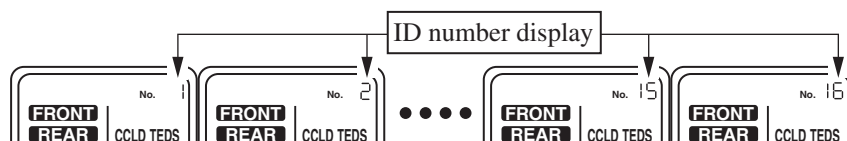

Important

If the ID number setting has been changed with the UV-22 connected, the UV-22 must be reset to recognize the change.

1. When you press the INPUT key on the operation panel of the UN-14 three times in succession, the ID number starts to flash.
2. Use the RANGE keys to set the number. When the setting is complete, press the MEAS key to enable the setting and return to the measurement screen.

Make the setting for each unit individually, so that each unit has a unique ID number.

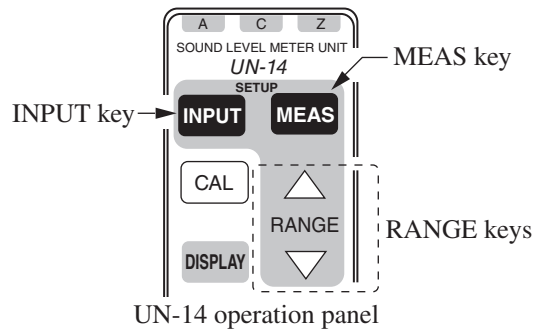

Note

When a TEDS sensor is connected and the FRONT CCLD TEDS setting is selected, pressing the INPUT key will automatically set the sensitivity. The ID number setup screen then appears.

Measurement setup mode

This mode serves for selecting the frequency weighting characteristics, time weighting characteristics, HPF (high-pass filter), and LPF (low-pass filter) settings.

Be sure to make or check these settings before starting a measurement.

	Settings
Time weighting characteristics	F, S, 10 ms
Frequency weighting characteristics	A, C, Z Indicated by [▼] on display screen
HPF setting	20 Hz, OFF
LPF setting	20 kHz, OFF

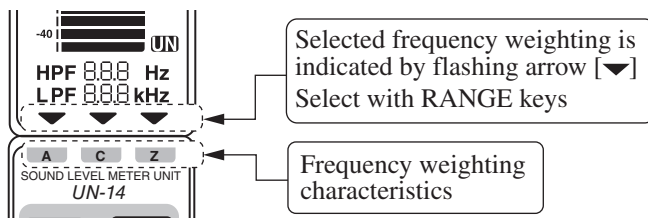

Setup procedure

- 1) Pressing the MEAS key in measurement mode allows you to set the time weighting characteristics.

You can change the setting with the RANGE keys.

F: FAST, time constant 125 msec

S: SLOW, time constant 1 sec

10 ms: Time constant 10 msec

When the setting is as required, press the MEAS key.

- 2) Pressing the MEAS key allows you to set the frequency weighting characteristics.

You can change the setting with the RANGE keys.

For details, see "Frequency Characteristics" on page 55.

A: Frequency weighting A characteristics

C: Frequency weighting C characteristics

Z: Frequency weighting Z characteristics

When the setting is as required, press the MEAS key.

- Pressing the MEAS key allows you to set the HPF (high-pass filter) setting.

You can change the setting with the RANGE keys.

- OFF: HPF set to OFF (display shows "---")
- 20 Hz: HPF set to 20 Hz

When the setting is as required, press the MEAS key.

- Pressing the MEAS key allows you to set the LPF (low-pass filter) setting.

You can change the setting with the RANGE keys.

- OFF: LPF set to OFF (display shows "---")
- 20 kHz: LPF set to 20 kHz

When the setting is as required, press the MEAS key.

- When you press the MEAS key, the changed settings become active and the setup procedure is completed.

If you press the INPUT key at any point during steps 1) to 4), the settings will become active and the unit switches to measurement mode immediately.

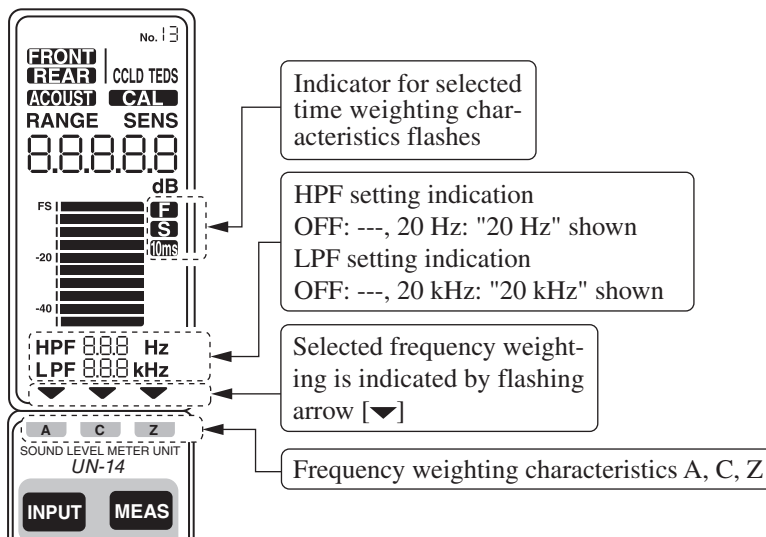

In measurement setup mode, all items that can be changed are shown, and the item currently being adjusted is flashing.

Calibration mode (OUTPUT CAL)

This mode serves for electrical calibration of external equipment connected to the BNC connectors on the rear panel.

Calibration procedure

1. Press the CAL key while the unit is in measurement mode.
2. While the CAL key is being held down, the AC OUT and DC OUT connectors on the rear panel supply a calibration signal for use as reference (range full-scale value -6 dB).

Example: 94.0 dB if level range is set to 100 dB

Calibration signal

AC OUT:	Sine wave 1 kHz	0.5 V (rms) $\pm 2\%$
DC OUT:	3.2 V $\pm 1\%$	

3. Press the CAL key again to return to the measurement mode.

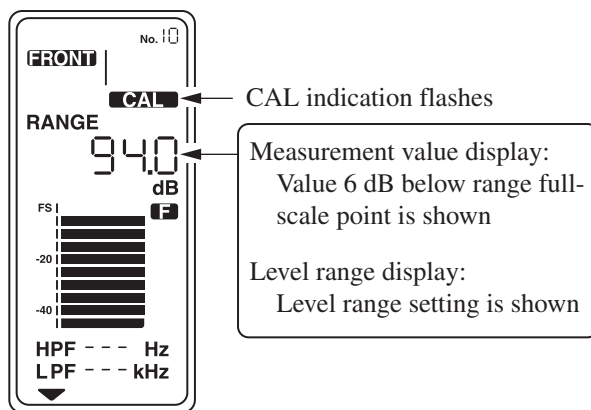

Note

In CAL mode, time weighting is set to F and HPF and LPF are set to OFF.

The unit returns to OUTPUT CAL mode, and pressing the CAL key again returns to measurement mode.

Measurement mode

This is the operation mode for performing sound level measurements.

The measurement value corresponding to the sound level magnitude is shown as a numeric indication and as a bar graph on the LCD panel. A corresponding AC signal and DC signal is also output from the respective connectors on the rear panel.

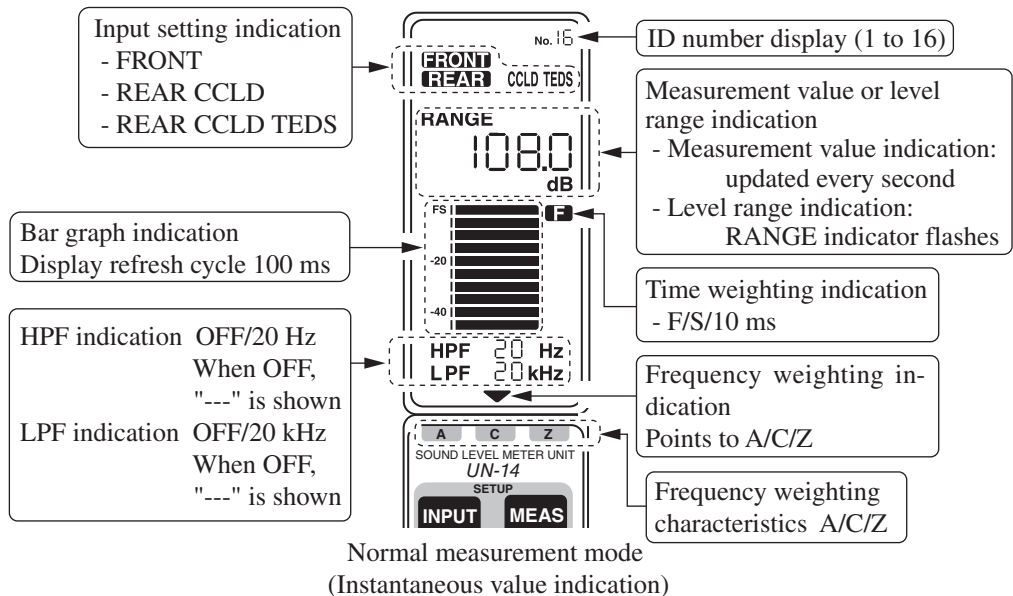

Changing the range

The RANGE keys can be used to change the range setting.

If the microphone signal is too high for the currently selected range, the internal amplification circuits will saturate, causing the red overload indicator LED to light up. In such a case, correct measurement is not possible, and you should change the range setting.

Level range setting range

Sensitivity value	Level range
-10.0 to -19.9	70 to 120 dB in 10-dB steps
-20.0 to -29.9	80 to 130 dB in 10-dB steps
-30.0 to -39.9	90 to 140 dB in 10-dB steps
-40.0 to -49.9	100 to 150 dB in 10-dB steps
-50.0 to -59.9	110 to 160 dB in 10-dB steps

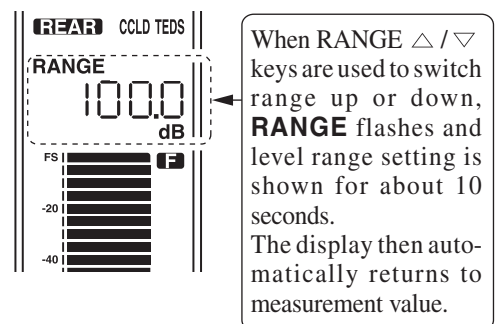

Overload indicator LED

At each range setting, measurement is possible up to a point about +8.5 dB higher than the range full-scale point.

For example, if the range setting is 120 dB, measurement is possible up to about 128.5 dB without saturation (signal waveform does not saturate).

When saturation of the internal circuits occurs, the red overload indicator LED lights up. In this case, correct measurement is not possible. Use the RANGE keys to change the level range setting so that the LED does not light up.

Overload indicator LED

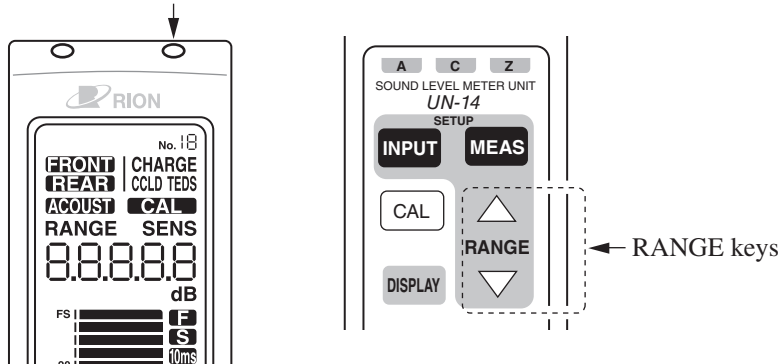

Bar graph indication

The bar graph indication consists of 10 bars.

The display refresh cycle is 100 msec.

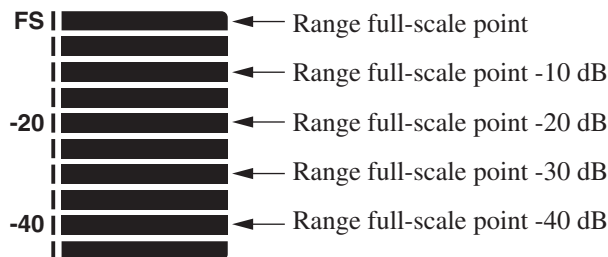

Relationship between AC OUT signal voltage and sound pressure level

The AC signal supplied at the AC OUT connector on the rear panel corresponds to the selected frequency weighting and HPF and LPF settings. The amplitude of the signal can be calculated from the selected range and the voltage value.

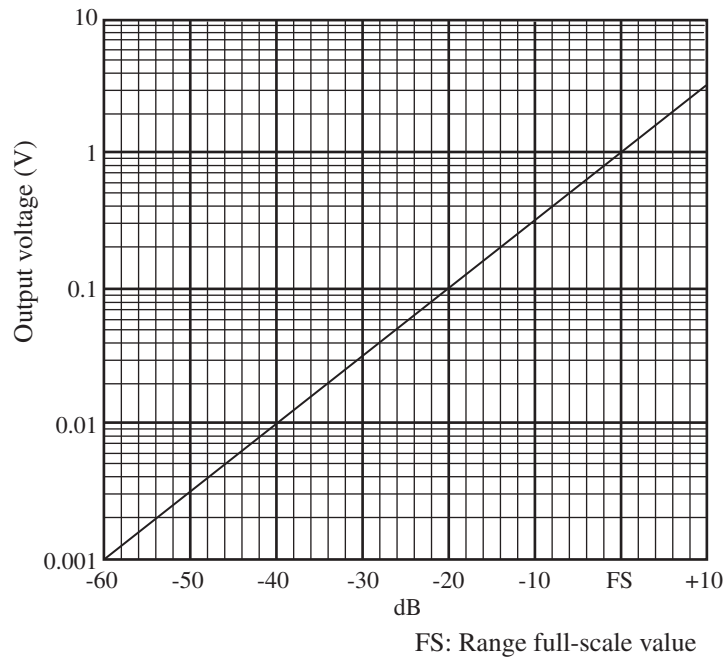

DC OUT signal

The DC signal supplied at the DC OUT connector on the rear panel is obtained by rms conversion of the AC signal using the selected time weighting characteristics.

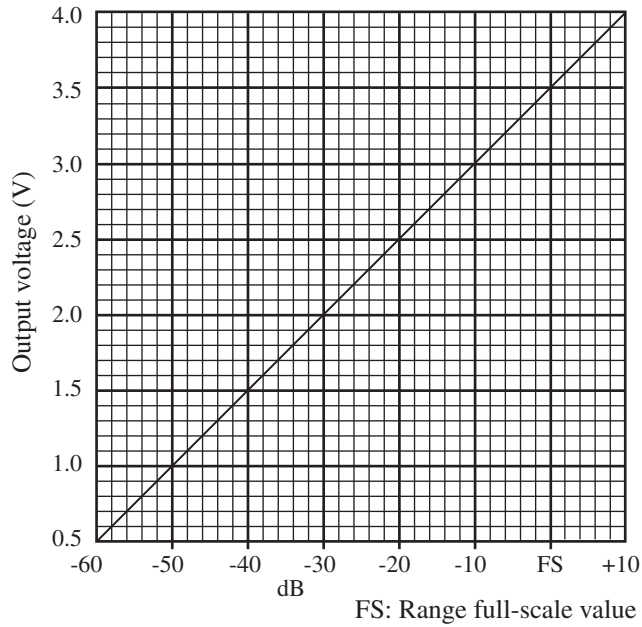

Example for level range 120 setting

Range	Output voltage	Setting value
120 dB	3.5 V	120 dB
	2 V	90 dB
	1 V	70 dB

Check mode

You can check the software version of the UN-14 as follows.

1. Pressing the CAL key while the unit is in measurement mode activates OUTPUT CAL mode.
2. Hold down the RANGE \triangle key for at least 2 seconds, until the version number is shown on the numeric readout of the LCD panel.
3. Press the MEAS key to return to the OUTPUT CAL mode.
4. Press the CAL key to return to measurement mode.

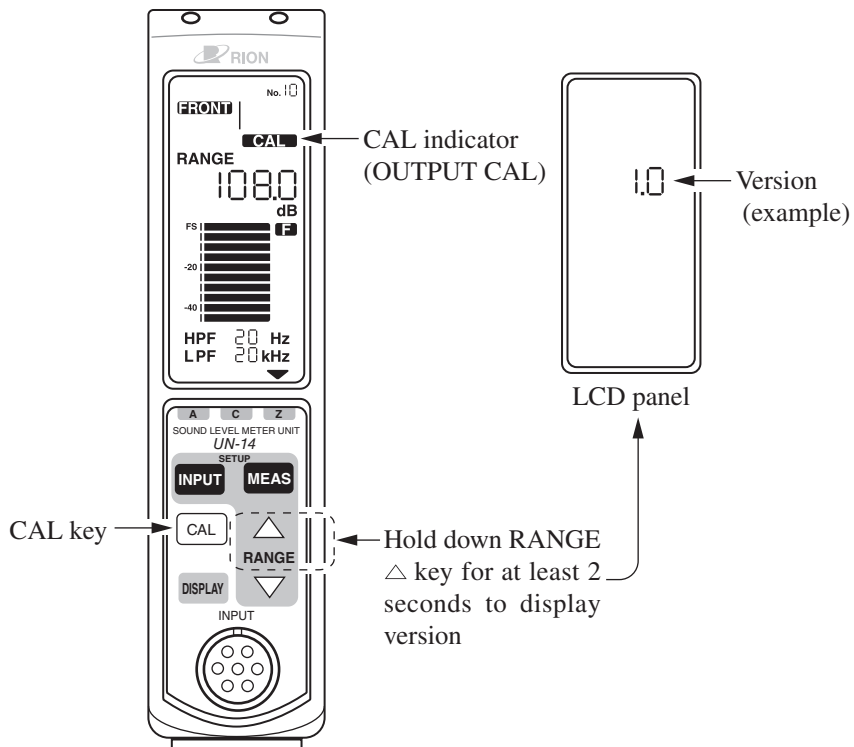

Using the Interface Unit UV-22 (option)

When the UV-22 is connected, the sound level and vibration measurement system can be controlled by sending commands from a computer, and measurement values can be transferred to the computer.

Both USB and Ethernet connections are supported.

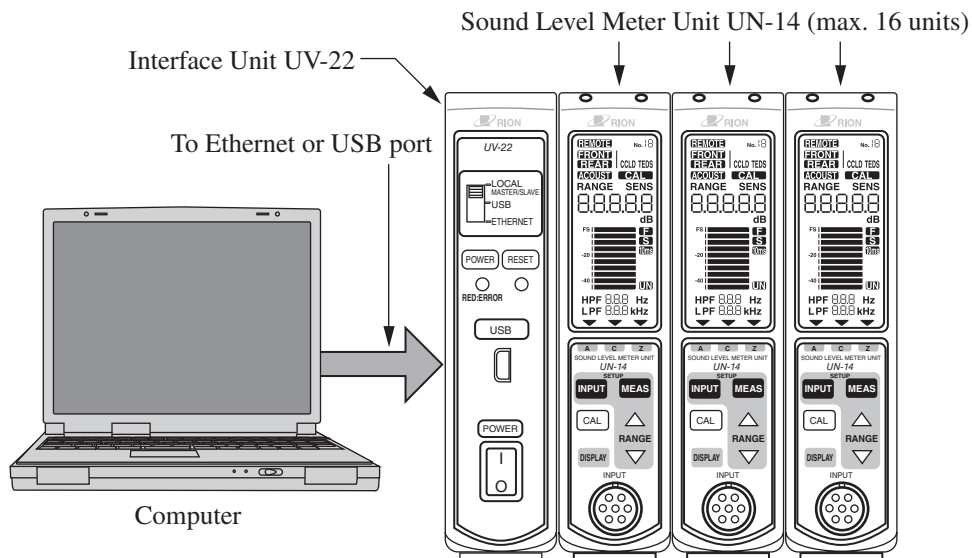

Main functions with UV-22 connected

- Setup control from computer
 - System setup can be performed from a computer, via a USB or Ethernet connection.
- Data transfer to computer
 - Measurement data can be sent to a computer, via a USB or Ethernet connection.

- User filter settings

One cutoff frequency as specified below can be added to the HPF and LPF settings.

For information on user filter frequencies, see pages 64 and 65 in the "Reference Material" section starting on page 62.

HPF cutoff frequency (attenuation -18 dB/oct):

Any center frequency from 3 Hz to 160 Hz can be specified, in 1/3 octave steps.

LPF cutoff frequency (attenuation -18 dB/oct):

Any center frequency from 300 Hz to 50 kHz can be specified, in 1/3 octave steps.

- Master/Slave function

When not connected to a computer, the settings of multiple units in a system can be changed from one unit using this function. This is useful to make the settings of multiple units identical.

Factory default settings

The factory default settings are as follows.

Input settings	INPUT:	FRONT
	Sensitivity:	-29.9 dB
	ID number:	1
	Level range:	120
	Numeric readout:	Measurement value
	Frequency weighting:	A
	Time weighting:	F
	HPF:	OFF (display shows ---)
	LPF:	OFF (display shows ---)

Restoring the factory default settings

Turning power to the unit on while holding down the MEAS key will clear the resume information and return the unit to the factory default settings listed above.

Performance Characteristics

Frequency response characteristics

The frequency weighting curves of the UN-14 (representative characteristics) are shown below.

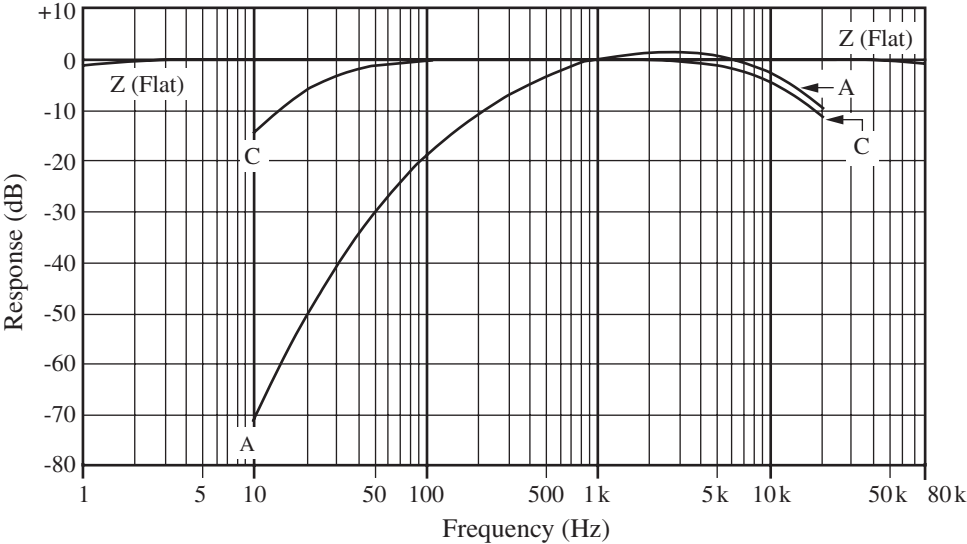

The representative characteristics of the built-in 20 Hz high-pass filter (HPF) and 20 kHz low-pass filter (LPF) are shown below.

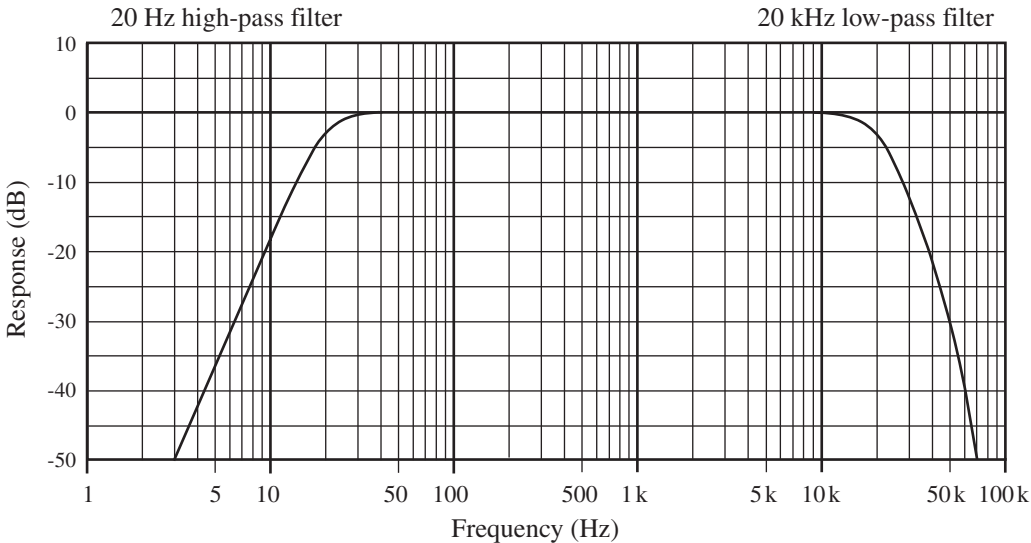

Influence of extension cable EC-04 series

Due to the capacitance between the signal lines and shield of the extension cable EC-04 series, there are limitations with regard to the maximum sound pressure and frequency that can be measured.

This phenomenon is plotted in the diagram below.

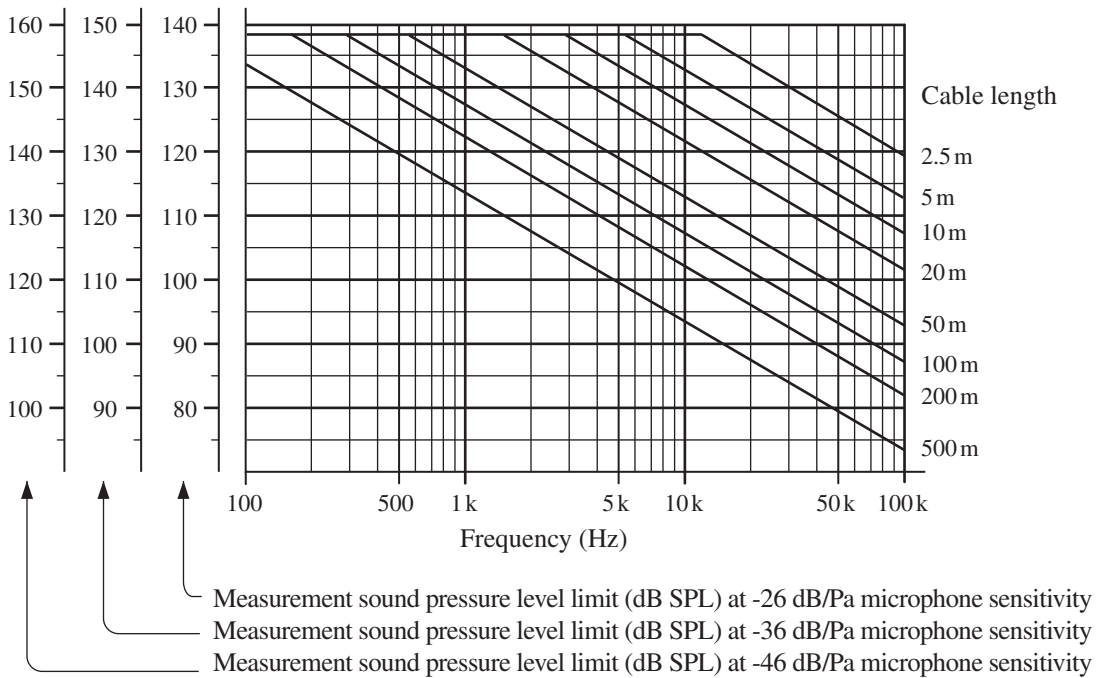

Example

When using a cable run of 50 meters with a microphone of -26 dB/Pa sensitivity to measure frequencies up to 10 kHz, the highest sound pressure level that can be measured is 110 dB.

Specifications

Inputs

Number of measurement channels

1

Connectors

7-pin input connector (on front panel)

For Rion measurement microphone or preamplifier

Max. input voltage ± 10 V

Microphone bias voltage +30 V, +60 V, +200 V

BNC connector (on rear panel)

For CCLD compliant microphone or preamplifier

TEDS compliance rating

IEEE 1451.4-2000 Template ID 12.27.28

CCLD power supply voltage/current 24 V 4 mA

Frequency weighting characteristics

A, C, Z (JIS C 1509-1 Class 1, IEC 61672-1 Class 1 electrical characteristics)

Measurement level range

A 30 to 128 dB (using UC-59)

C 36 to 128 dB (using UC-59)

Z 41 to 128 dB (using UC-59)

(HPF 20 Hz, LPF 20 kHz)

Frequency range

1 Hz to 80 kHz

(20 Hz to 40 kHz ± 0.5 dB)

(1 Hz to 80 kHz ± 3 dB)

Sensitivity setting

Setting range -10.0 to -59.9 dB/Pa in 0.1-dB/Pa steps

Level range settings

6 settings

Sensitivity value	Level range
-10.0 to -19.9	70 to 120 dB in 10-dB steps
-20.0 to -29.9	80 to 130 dB in 10-dB steps
-30.0 to -39.9	90 to 140 dB in 10-dB steps
-40.0 to -49.9	100 to 150 dB in 10-dB steps
-50.0 to -59.9	110 to 160 dB in 10-dB steps

Calibration output signal (for calibration of subsequent equipment)

AC output Sinusoidal wave 1 kHz $\pm 2\%$,
output signal 0.5 V (rms) $\pm 2\%$

DC output +3.2 V $\pm 1\%$

Time weighting characteristics

F, S, 10 ms (IEC 61672-1 Class 1, JIS C 1509-1 Class 1 electrical characteristics)

Display

Segment-type LCD with backlight (backlight constantly on when powered from AC adapter)

Display contents

Unit settings, instantaneous value (1-sec cycle),
bar graph (100-msec cycle)

Warning indications

LED $\times 2$

Right-side LED

Normally off; lights up in red to indicate overload

Left-side LED

Master/Slave indication (when linked to UV-22)

Filters

HPF (attenuation -18 dB/oct, -3 dB drop)

20 Hz, OFF

LPF (attenuation -18 dB/oct, -3 dB drop)

20 kHz, OFF

Output

BNC connector

AC output	Output impedance	600 Ω
	Output voltage	1 V (rms) $\pm 2\%$ at range full-scale point
	Max. output voltage	± 5 V (peak) (no overload)
	Dynamic range	80 dB or more (1 Hz to 80 kHz)
		85 dB or more (20 Hz to 20 kHz)
Load impedance	10 k Ω or more	
DC output	Output impedance	50 Ω
	Output voltage	+3.5 V $\pm 1\%$ at range full-scale point (0.5 V/10 dB)
	Max. output voltage	+5 V
	Dynamic range	40 dB or more (1 Hz to 80 kHz)
		60 dB or more (20 Hz to 20 kHz)
Output impedance	10 k Ω or more	

Inherent noise

Input converted inherent noise

4 μ V (rms) or less	(Z, 1 Hz to 80 kHz)
2 μ V (rms) or less	(Z, 20 Hz to 20 kHz)
1.5 μ V (rms) or less	(A, C)

Power supply

9 to 15 V DC
Front (using NH-17, UC-59): approx. 150 mA (12 V)
Rear (using NH-22, UC-59): approx. 170 mA (12 V)
Suitable AC adapter
NC-99: (max. 16 UN-14 units and one UV-22) (CE mark)
Max. 85 VA with 16 UN-14 units (100 V AC)
NC-97: (max. 10 UN-14 units and one UV-22)
Battery Unit BP-17

Resume function

Memorizes all settings at power-off and restores the settings at the next power-on.

ID number function Serves to uniquely identify the unit in a system with up to 16 units, used in conjunction with UV-22.
Maximum number of units: 16

Temperature and humidity conditions for use and storage
-10 to +50°C, max. 90% RH (no condensation)

Dimensions, Mass 150 (H) × 36 (W) × 179 (D) mm (excl. protruding parts)
Approx. 500 g

Supplied accessories

Link plate	1
Instruction manual	1
Inspection certificate	1

Optional accessories

Interface Unit	UV-22
Vibration Meter Unit	UV-15
AC adapter	NC-99 (max. 16 UN-14 units and one UV-22) (CE mark) NC-97 (max. 10 UN-14 units and one UV-22)
Battery Unit	BP-17
Measurement microphone	Various
Preamplifier	Various
CCLD preamplifier	Various
BNC-BNC cable	NC-39A
BNC-BNC coaxial cable	EC-90A (2 m) EC-90B (5 m)
7-pin microphone extension cable	EC-04 series

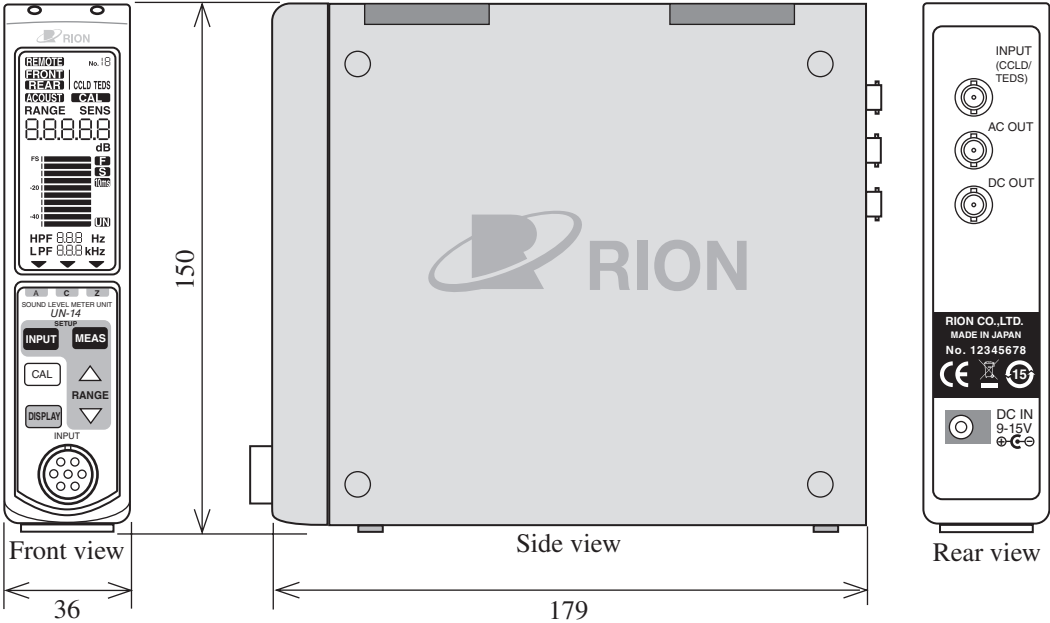

Unit: mm

Dimensional Drawing

Reference Material

Group Delay

The UN-14 incorporates an A/D converter which converts the microphone input signal into digital format for processing by a DSP chip. The result is then returned to analog format by a D/A converter and output as an AC and DC signal. Due to this process, the output signal has a constant delay (group delay) with regard to the microphone input signal, as shown below. This should be taken into consideration when using the unit.

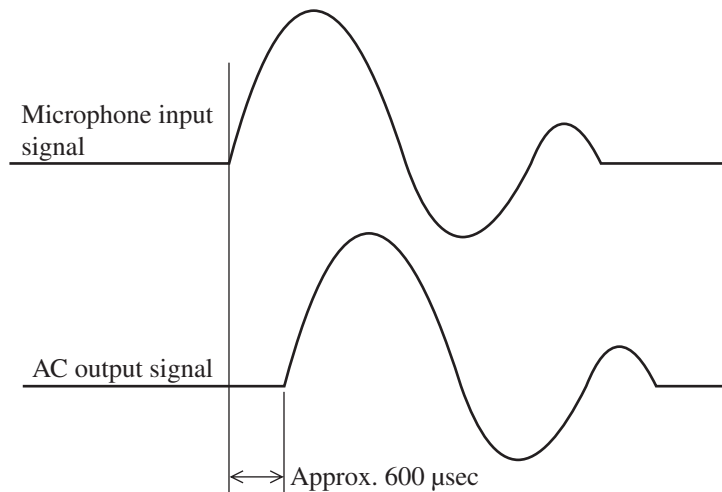

Measurement Range

The frequency and level range that can be measured depends on the combination of microphone and preamplifier.

Frequency range (representative characteristics)

The measurement frequency range specifications of various microphones are indicated below.

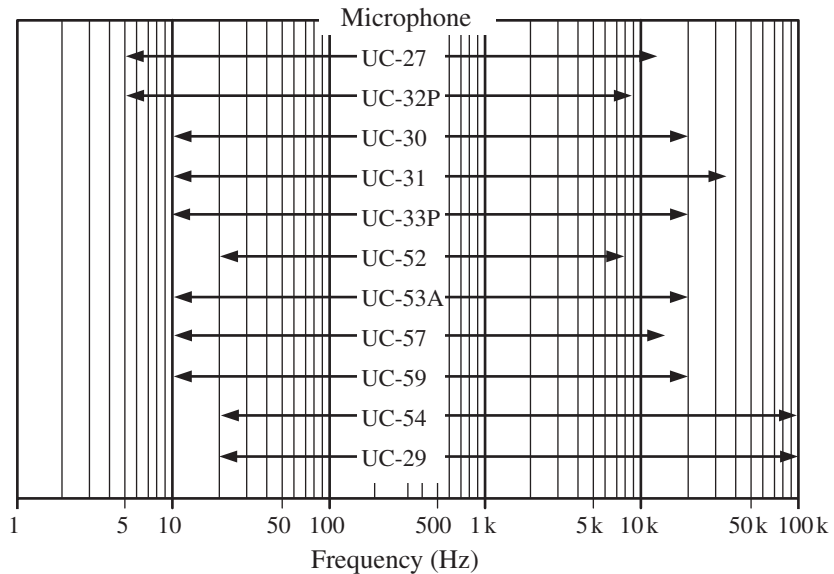

Measurement level range

The measurement level range specifications of various microphones are indicated below (A weighting, representative characteristics).

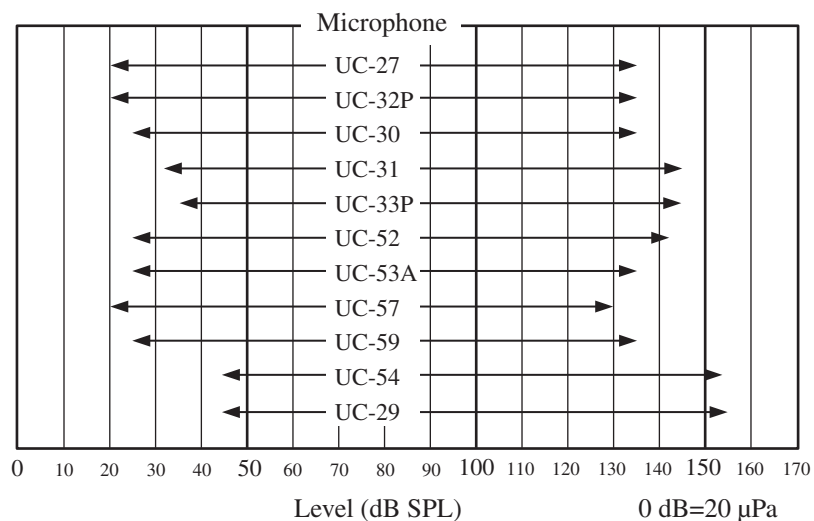

User Filter

When used in conjunction with the UV-22, one each of the HPF and LPF characteristics shown below can be added as a user filter.

Available user filter frequency characteristics are as follows.

UN-14 user filter characteristics for HPF

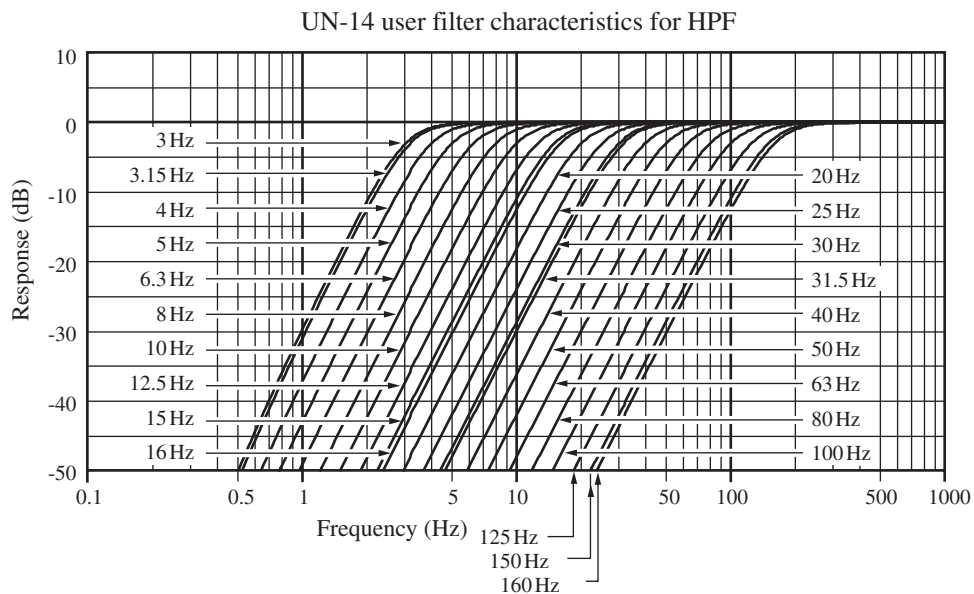

HPF (high-pass filter cutoff frequency: -3 dB drop)

3 Hz, 3.15 Hz, 4 Hz, 5 Hz, 6.3 Hz, 8 Hz, 10 Hz, 12.5 Hz, 15 Hz, 16 Hz,
20 Hz, 25 Hz, 30 Hz, 31.5 Hz, 40 Hz, 50 Hz, 63 Hz, 80 Hz, 100 Hz,
125 Hz, 150 Hz, 160 Hz

Attenuation: -18 dB/oct

UN-14 user filter characteristics for LPF

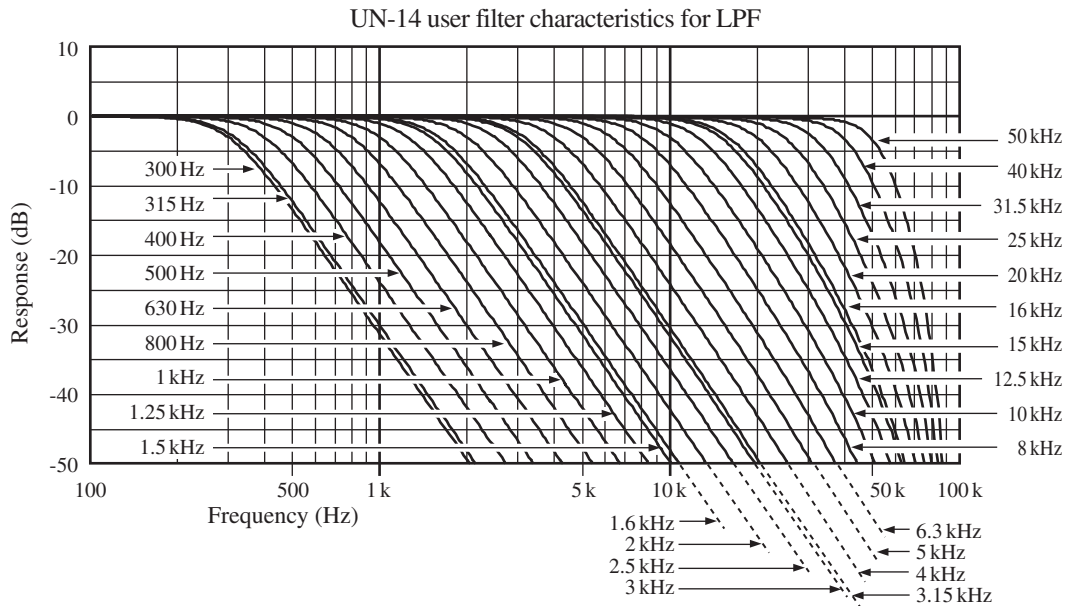

LPF (low-pass filter cutoff frequency: -3 dB drop)

300 Hz, 315 Hz, 400 Hz, 500 Hz, 630 Hz, 800 Hz, 1 kHz, 1.25 kHz,
 1.5 kHz, 1.6 kHz, 2 kHz, 2.5 kHz, 3 kHz, 3.15 kHz, 4 kHz, 5 kHz,
 6.3 kHz, 8 kHz, 10 kHz, 12.5 kHz, 15 kHz, 16 kHz, 20 kHz, 25 kHz,
 31.5 kHz, 40 kHz, 50 kHz

Attenuation: -18 dB/oct

Maintenance parts

If parts such as link hook, cover plate, or screws were lost by mistake, contact the supplier to obtain replacements.

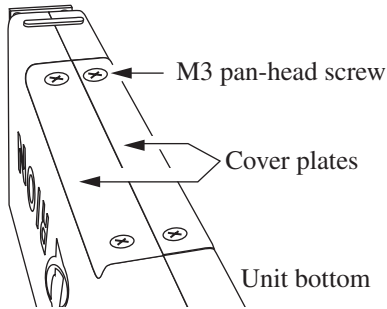

Part name: Cover plate
Part number: UV-16-008

Part name: M3 pan-head screw
Rion designation: KS 3 × 10
Conventional market designation:
Pan-head screw M3 × 10
Screw length 10 mm

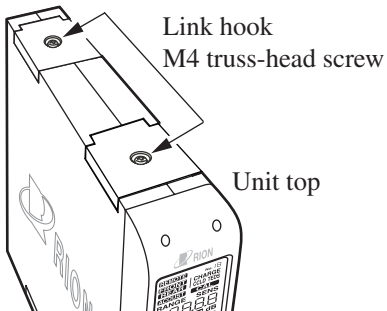

Part name: Link hook
Part number: UV-16-004

Part name: M4 truss-head screw
Rion designation: KT 4 × 8
Conventional market designation:
Truss-head screw M4 × 8
Screw length 8 mm

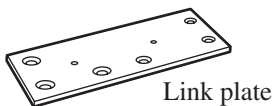

Part name: Link plate
Part number: UV-16-007

